

OPTIONAL TOOL ADAPTER:
FOR USE WITH DIE SETS
(4) LENGTHS AVAILABLE

SECTION Y-Y
SCALE 1 : 4

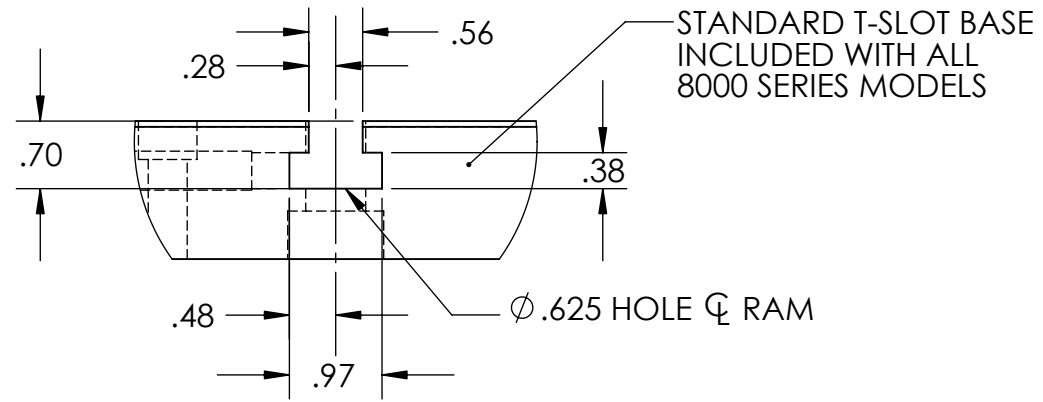

DETAIL X
SCALE 1 : 2

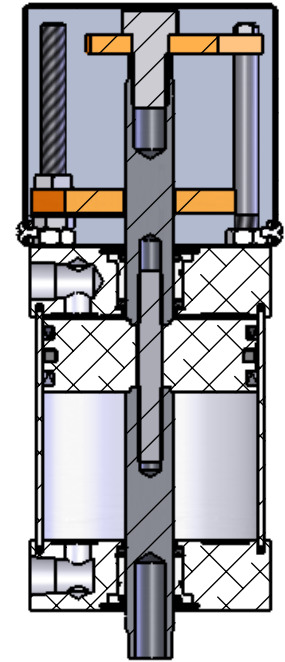

SECTION Z-Z
SCALE 1 : 4

ADJUSTABLE DOWN STOP/
ANTI-ROTATE MECH.

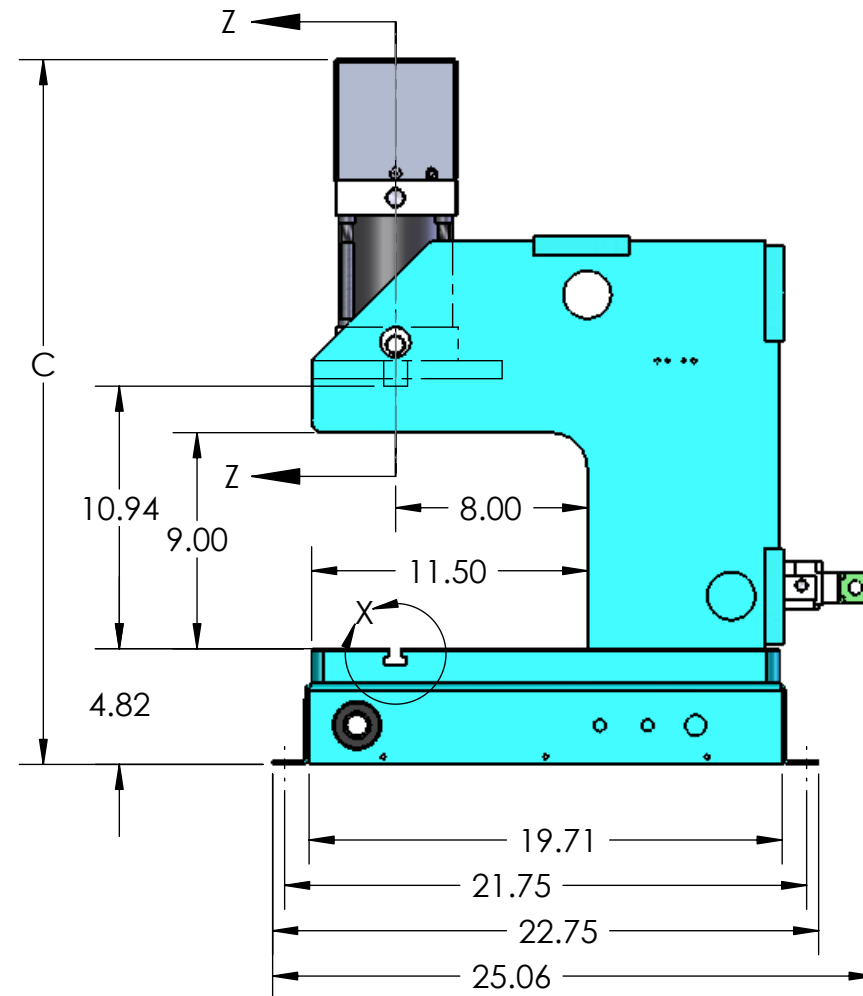
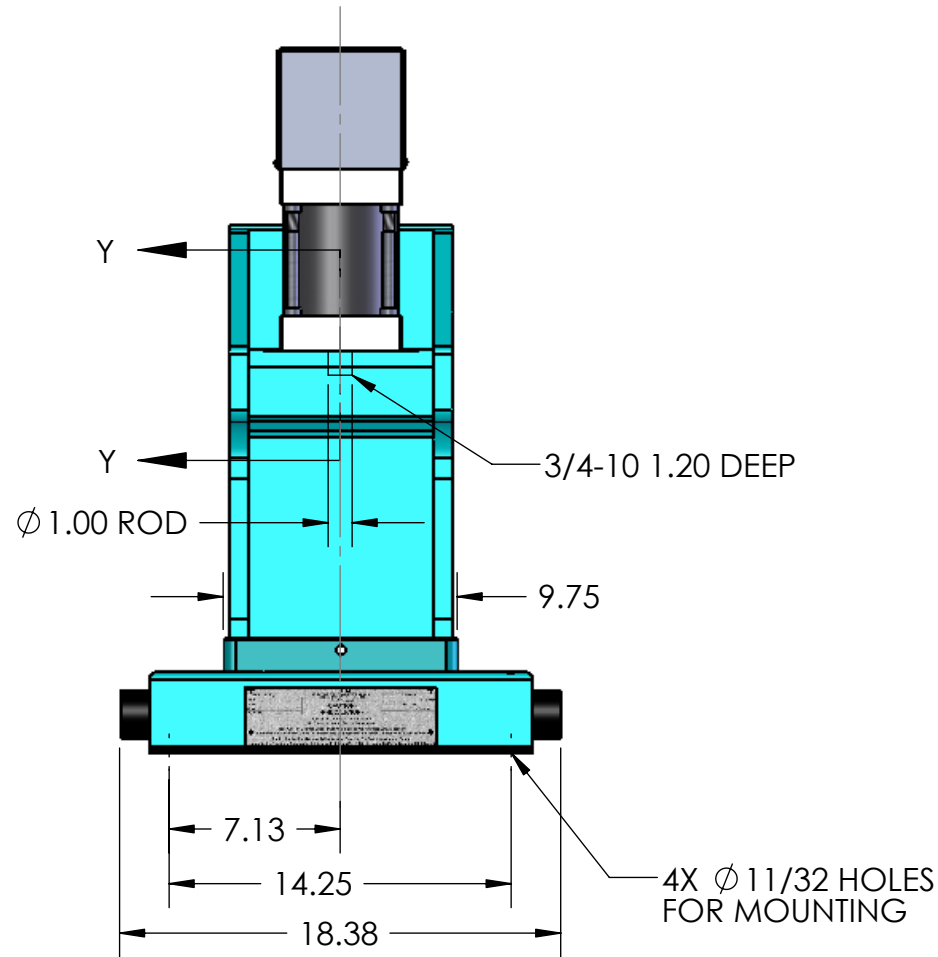

MODEL #	C DIM.
A-8151	29.37
A-8302	34.99
A-8453	41.71

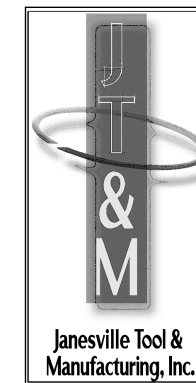

Janesville Tool & Manufacturing Inc.
1352 East High Street
Milton WI 53563
Phone 608-868-4711 Fax 608-868-4925

TITLE:
A-8000 SERIES

SIZE B	DWG. NO. A-8000	REV A
------------------	---------------------------	-----------------

SCALE: 1:12 WEIGHT: SHEET 1 OF 1