

## Cylinder Information

|                |   |               |
|----------------|---|---------------|
| Model AP-5302  | 2 Stage 4—1/2" Bore x 3" Stroke Double End<br>Repair Kit 4—1/2" Bore Double End—2 Stage | 617<br>617-RK |
| Model AP-5453  | 3 Stage 4—1/2" Bore x 3" Stroke Double End<br>Repair Kit 4—1/2" Bore Double End—3 Stage | 619<br>619-RK |
| Model AP-5604  | 4 Stage 4—1/2" Bore x 3" Stroke Double End<br>Repair Kit 4—1/2" Bore Double End—4 Stage | 621<br>621-RK |
| Model AP-9812  | 3 Stage 6" Bore x 3" Stroke Double End<br>Repair Kit 6" Bore Double End—3 Stage         | 629<br>629-RK |
| Model AP-91082 | 4 Stage 6" Bore x 3" Stroke Double End<br>Repair Kit 6" Bore Double End—4 Stage         | 631<br>631-RK |



3930 Enterprise Drive  
Janesville, WI 53546

P.O. Box 67  
Milton, Wisconsin 53563

Phone 608/314-1620  
Fax 608/314-1625

[www.janesvilletool.com](http://www.janesvilletool.com)  
[sales@janesvilletool.com](mailto:sales@janesvilletool.com)

4/21



USER NAME 4711

SERIAL# \_\_\_\_\_

AP-9000 SERIES

AP-9302

AP-9453

AP-9604

AP-9812

AP-91082

3930 Enterprise Drive  
Janesville, WI 53546

P.O. Box 67  
Milton, Wisconsin 53563

Phone 608/314-1620  
Fax 608/314-1625

[www.janesvilletool.com](http://www.janesvilletool.com)  
[sales@janesvilletool.com](mailto:sales@janesvilletool.com)

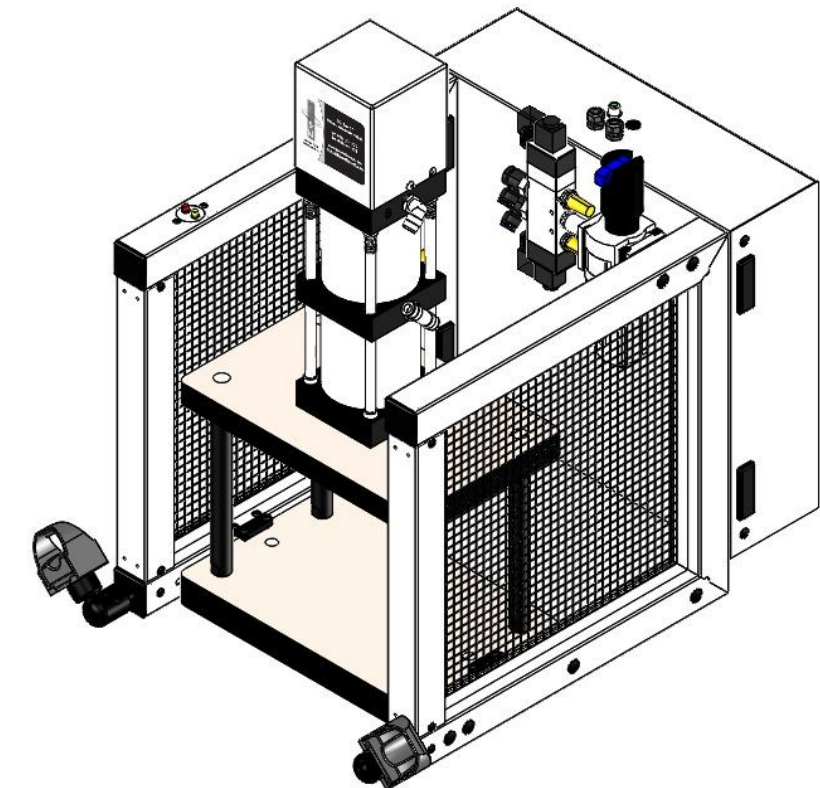

## Unpacking and Setup

For shipping purposes, the Banner Opto-Touch® buttons are positioned so that shipping damage is minimized. Locate the set screws at the mounting brackets and loosen with an Allen wrench. Position the Banner Opto-Touch® buttons to the desired position and tighten set screws for the press operation.

Power Cord is located inside the main control box. The receptacle for the power cord is located on the left side of the press on the main control box.

## Safety Instructions

**DO NOT OPERATE PRESS WITH GUARDS REMOVED.**

**ALL SAFETY DEVICES MUST BE INSTALLED AND OPERABLE.**

**ADDITIONAL GUARDING IS REQUIRED FOR SPECIAL TOOLING.**

**DISCONNECT PRESS** when not in use, before servicing, and when changing accessories, such as down stops and tooling.

**WEAR SAFETY GLASSES WHILE OPERATING PRESS.**

**GUARD AGAINST ELECTRIC SHOCK.** Do not use in damp locations.

**DRESS PROPERLY.** Do not wear loose fitting clothing or jewelry that could get caught in moving parts.

**KEEP HANDS AWAY.** Never reach near moving parts.

**DO NOT OPERATE PRESS OVER 100 PSI.** Excess pressure may cause damage or injury.

**DO NOT OPERATE PRESS OVER LABELED VOLTAGE.**

**WATCH FOR DAMAGED PARTS.** If press is damaged during operation, examine the damaged part carefully to ensure that it will operate properly. If in doubt, replace the damaged part. Check for alignment of moving parts, binding of moving parts, mounting and any other conditions that may affect its operation.

**KEEP WORK AREA CLEAN.** Cluttered areas and benches invite injuries.

**STAY ALERT.** Watch what you are doing. Use common sense.

**FLOW CONTROLS** – To alter the ram descent speed on you JT&M Press, adjust the screw marked B located on the valve at the rear of the press. To alter the ram ascent speed, adjust screw A. (The ram retraction speed has been preset by the factory.) Rotate the screws clockwise to decrease the speed of the ram.

**PRESS OPERATION** – To operate press, push palm buttons in at the same time. Hold the palm buttons in until the down stroke is completed.

### To Remove Press from Guarding for Special Tooling

1. Remove four (4) button head screws located on the base of the press.
2. Remove the quick disconnect connector located on top of the main control box. Item #54 on parts drawing page 6.
3. Remove the air lines from the cylinder at ports “A” and “B”. These fittings are push to fit fittings and require the outer ring of the fitting to be pushed in as you pull the black flexible tube away from the fitting.

### Model AP-9000

| ITEM NO. | PART NO. | DESCRIPTION   | QTY. |
|----------|----------|---|------|
| 1        | 8000-21  | LARGE BACK PANEL  | 1    |
| 2        | 8000-32  | MOUNTING BRACKET (9000 SERIES)                          | 2    |
| 3        | 8000-101 | CONTROL BOX ASSEMBLY                                    | 1    |
| 4        | 8000-201 | LEFT GUARD ASSEMBLY (AP-9302, 9453, 9604, 9812, 91082)  | 1    |
| 5        | 8000-202 | RIGHT GUARD ASSEMBLY (AP-9302, 9453, 9604, 9812, 91082) | 1    |
| 6        | 8000-305 | VALVE AND REGULATOR ASSEMBLY (AP-9302, 9453, 9604)      | 1    |
| 7        | 8000-306 | VALVE AND REGULATOR ASSEMBLY (AP-9812, 91082)           | -    |
| 8        | 9000-01  | PRESS TOP (AP-9302, 9453, 9604)                         | 1    |
| 9        | 9000-02  | PRESS BASE (9000 SERIES)                                | 1    |
| 10       | 9000-03  | SUPPORT POST  | 4    |
| 11       | 9000-04  | PRESS TOP (AP-9812, 91082)                              | -    |
| 12       | 3000-35  | TOP GUARD (617, 619, 621 CYLINDER)                      | 1    |
| 13       | 1800-15  | TOP GUARD (629 & 631 CYLINDER)                          | -    |
| 14       | 906      | OPTICAL SWITCH  | 2    |
| 15       | 617      | 4.5" BORE X 3" STROKE 2-STAGE CYLINDER- DOUBLE END      | 1    |
| 16       | 619      | 4.5" BORE X 3" STROKE 3-STAGE CYLINDER- DOUBLE END      | -    |
| 17       | 621      | 4.5" BORE X 3" STROKE 4-STAGE CYLINDER- DOUBLE END      | -    |
| 18       | 629      | 6" BORE X 3" STROKE 2-STAGE CYLINDER- DOUBLE END        | -    |
| 19       | 631      | 6" BORE X 3" STROKE 3-STAGE CYLINDER- DOUBLE END        | -    |
| 20       | 925      | BULKHEAD CONNECTOR 12 PIN                               | 1    |

Pneumatic Schematic

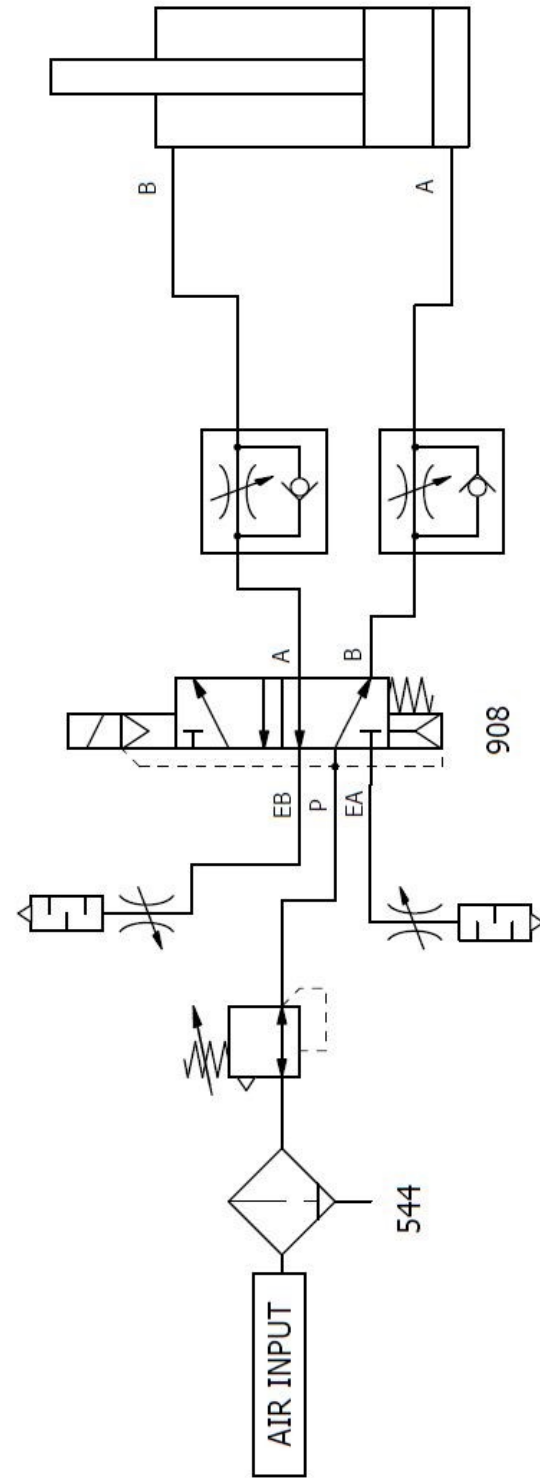

Electrical Schematic

PLEASE SEE INSERT

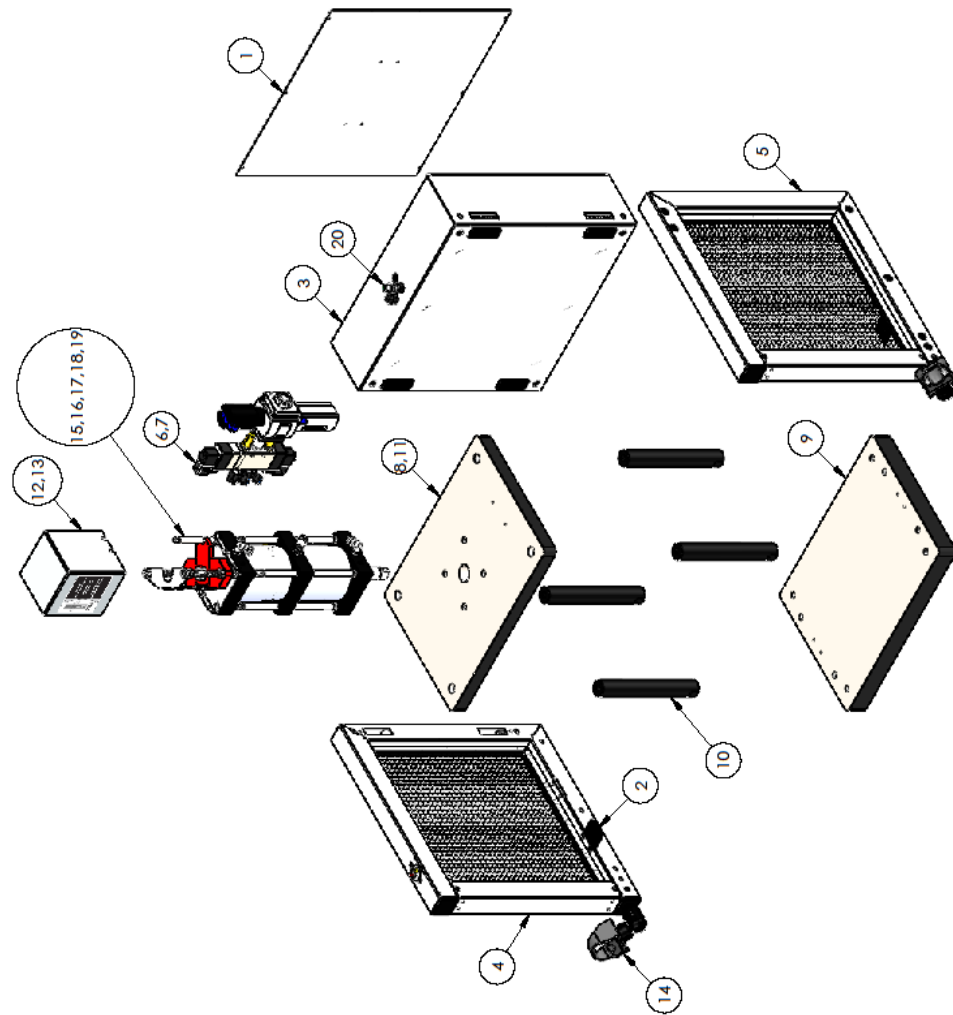

- At this point, the press frame is separated from the press controls and special machining and tooling can be installed. **Warning—guarding needs to be replaced for safe operation. Special tooling may require additional guarding for complete safe operation.**

The black wire mesh can be removed from each side for production of parts that will not fit in between guarding. Simply remove four (4) button head screws located on the top and bottom of the front tube. (item 18 on page 6) Once screws are removed, pull the front tube towards the front of the press. The black mesh can be removed once the front tube is gone. **Warning—special tooling requires special guarding if mesh is removed additional guarding is required for complete safe operation.**

### AP—Series with T10AP Timer

#### T10AP Operation

- Both “buttons” are actuated within on half second of each other and the cylinder advances toward the switch (570C). If one or both “buttons” are released before reaching the switch, the cylinder will retract
- The limit switch is located by you. This switch turns on the amber light and begins the delay of the down position. Once the amber light is on, the operator may keep hands on “buttons” or remove them and cylinder stays advanced.
- When timer completes its delay (.1sec to 999 hours for external), a red light is lit. If the operator left hands on “buttons” the cylinder will retract, or if hands were removed both “buttons” will need to be pressed and cylinder retracts.
- The press is ready for the next cycle once both hands are removed from the “buttons”.

External Timer adjustment:

Use mode C, on left side of timer.

Set right side of timer for time units

To change time settings, push button over the digit to reduce number and under digit to enlarge number.

### Emergency Stop Recovery

In case of an emergency press the e-stop button located on the top right corner of the press, by pressing the e-stop button you will disable all the functionality of the press.

To **reset** the E-Stop follow the steps below:

- Depress the e-stop button by twisting the button clockwise and pulling.
- On the top left corner press the home push button this will allow the press to be activated to retract the cylinder.
- Push the two opto push buttons simultaneously and hold to send the press back up to home position.
- Once the press is in the home position press the reset push button located in the top left corner of the press; the press is now set to normal functionality.