

REGULATED PRESSURE	FORCE
60 PSI	3726
80 PSI	4968
100 PSI	6210

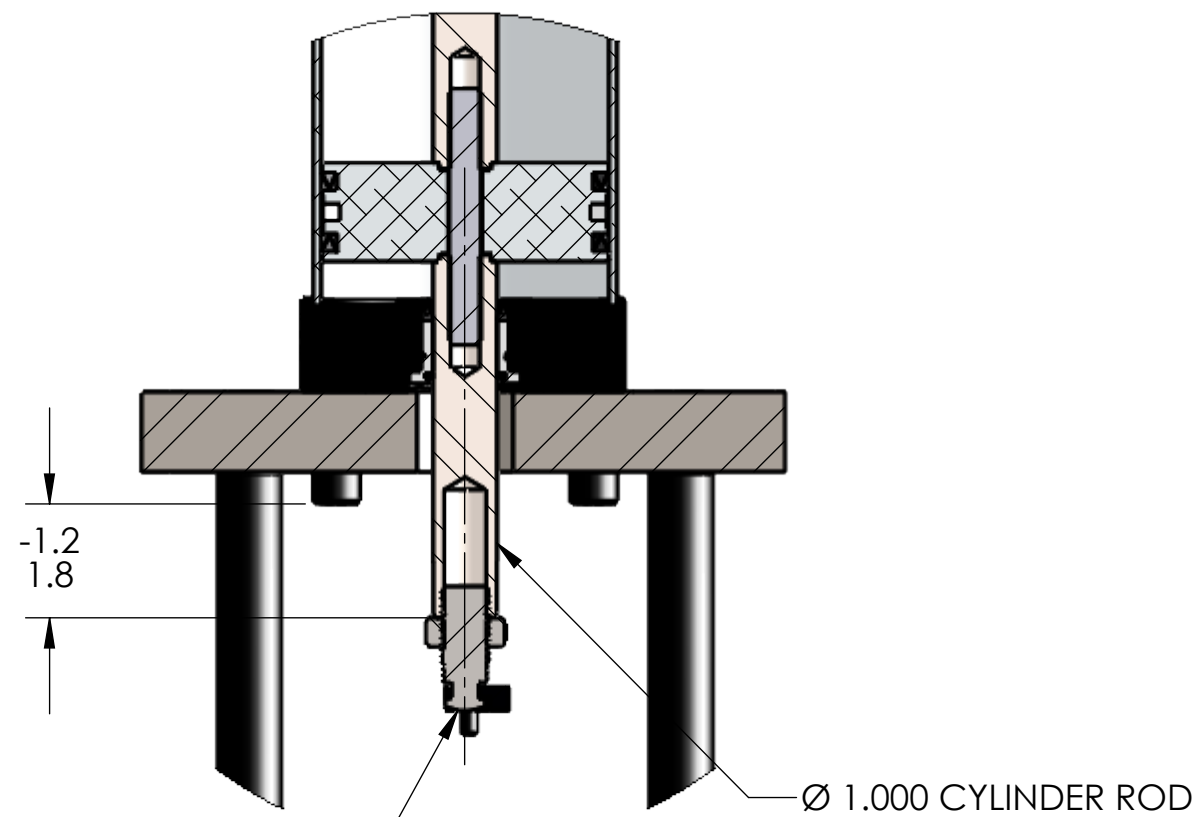
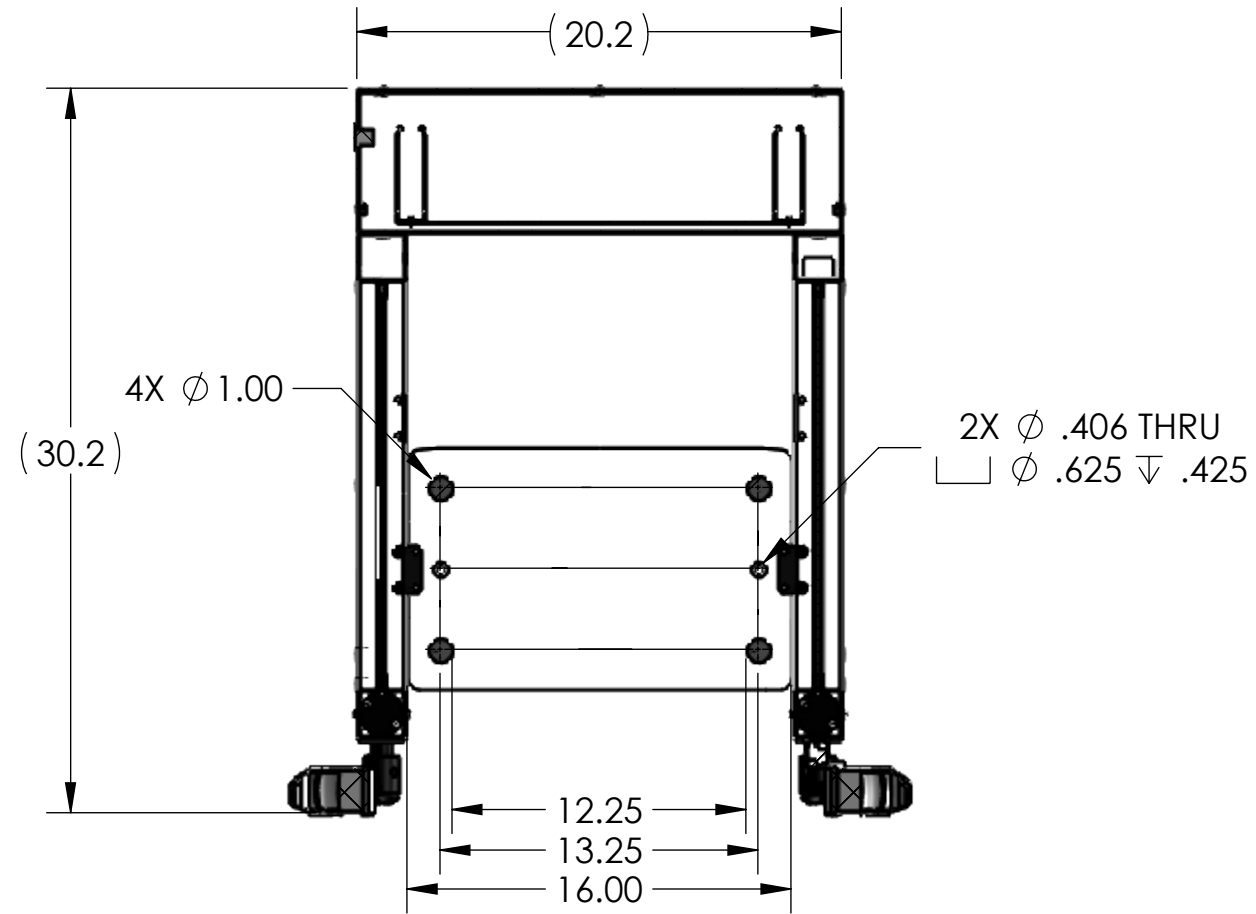

OPTIONAL TOOL ADAPTER:
FOR USE WITH DIE SETS
(3/4"-10 UNC ∇ 1.50)
(4) LENGTHS AVAILABLE

DETAIL D
SCALE 1 : 3

FRONT TUBES & WIRE MESH ARE REMOVABLE

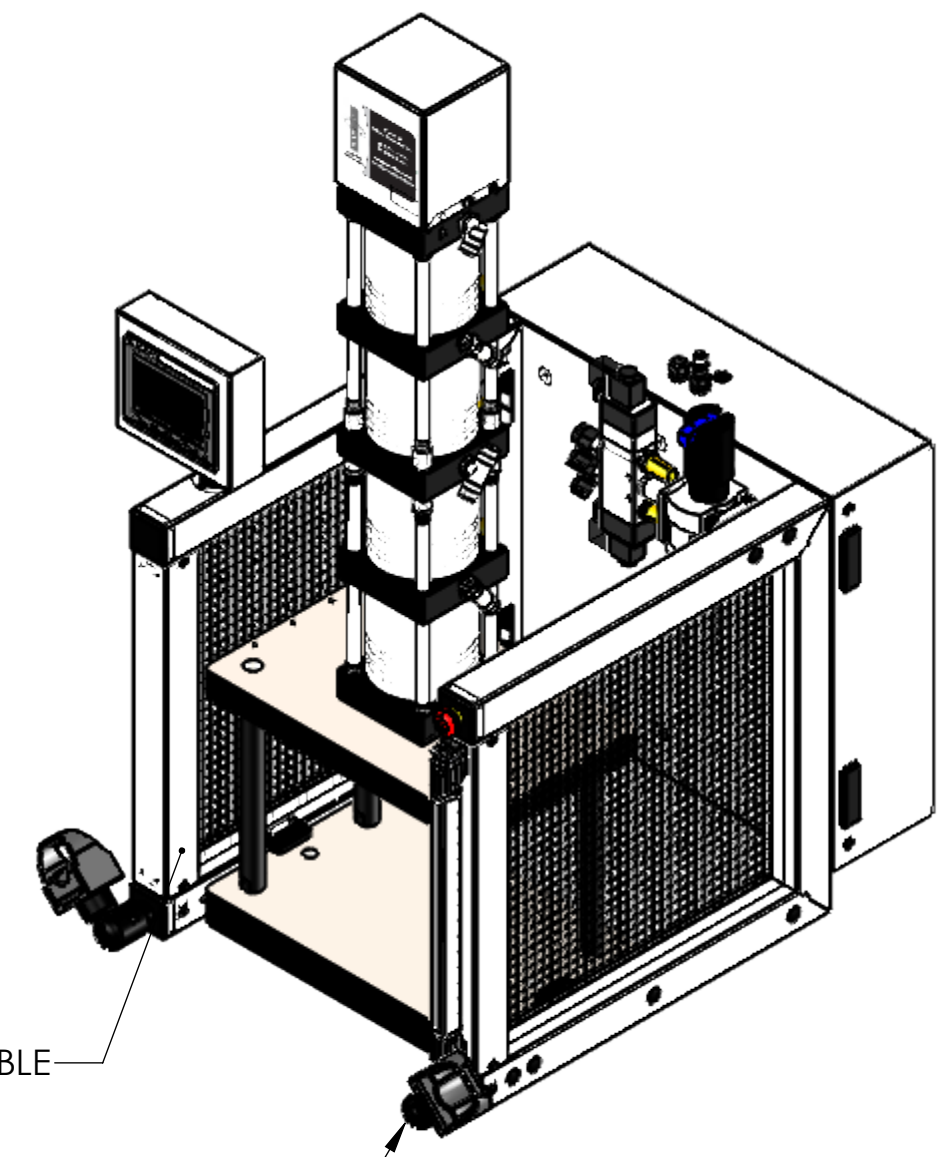

FULLY ADJUSTABLE OPTO TOUCH BUTTONS

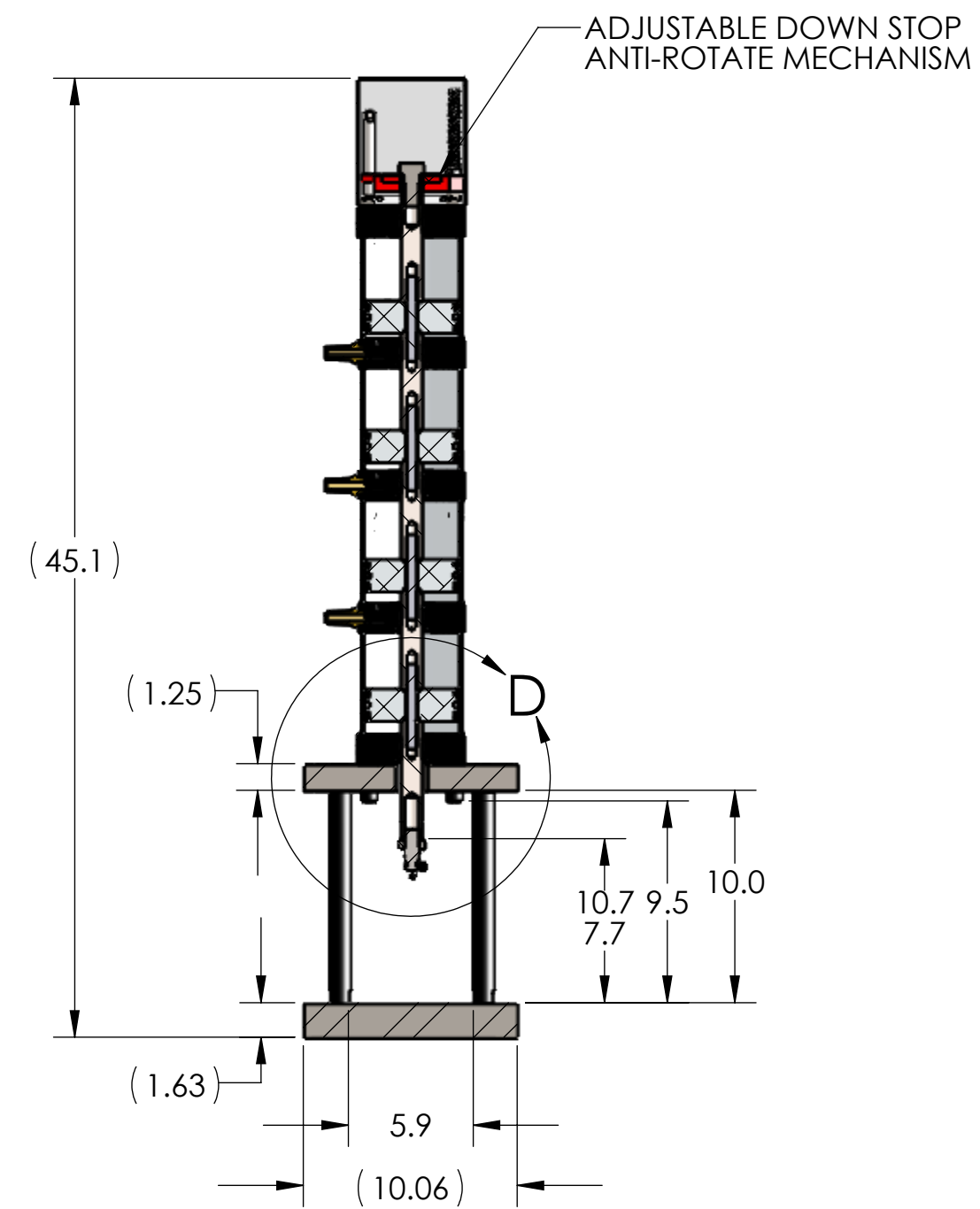
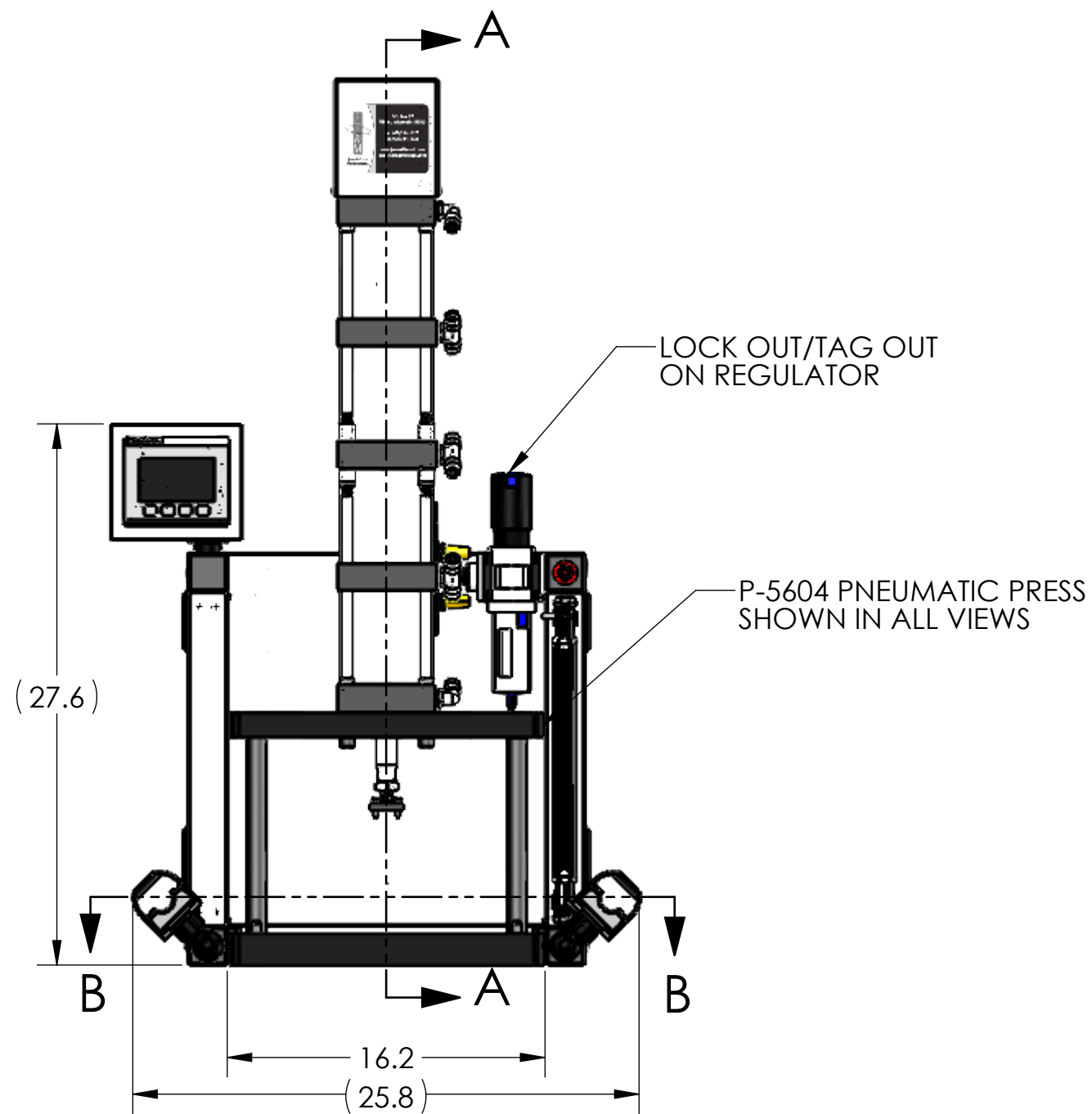

NOTES:

- PRESS OPERATES ON LOW VOLTAGE (24V DC).
- LED LIGHT COMES STANDARD.
- OPTIONAL FORCE MONITORING SYSTEM AVAILABLE UPON REQUEST (NOT SHOWN).
- CYLINDER ROD SHOWN IN EXTENDED POSITION.
- ALL CYLINDERS COME STANDARD WITH 3" OF STROKE.
LONGER CYLINDER STROKE LENGTHS AVAILABLE UPON REQUEST (UP TO 12").
- PRESS COMES STANDARD WITH 10" LONG POSTS.
ALTERNATE POST LENGTHS AVAILABLE UPON REQUEST (UP TO 18").
- LIGHT CURTAIN, E-STOP AND TOOL ADAPTER SHOWN DOES NOT COME STANDARD.
- REMOVED GUARD IN RIGHT VIEW FOR CLARITY.

THIS DRAWING WAS PRINTED ON 1/29/2021

UNLESS OTHERWISE SPECIFIED:		NAME	DATE
DIMENSIONS ARE IN INCHES		DRAWN	RKM 1/29/21
TOLERANCES:		CHECKED	
FRACTIONAL: ± 0.15		ENG APPR.	
ANGULAR: MACH ± 0.5 BEND ± 0.5		MFG APPR.	
TWO PLACE DECIMAL ± 0.01		Q.A.	
THREE PLACE DECIMAL ± 0.005		COMMENTS:	
FOUR PLACE DECIMAL ± 0.0005			
INTERPRET GEOMETRIC TOLERANCING PER: ASME Y14.5-1994			
MATERIAL			
SEE DETAILS			
FINISH			
SEE DETAILS			
DO NOT SCALE DRAWING			

PROPRIETARY AND CONFIDENTIAL
THE INFORMATION CONTAINED IN THIS DRAWING IS THE SOLE PROPERTY OF JANSVILLE TOOL & MANUFACTURING INC. ANY REPRODUCTION IN PART OR AS A WHOLE WITHOUT THE WRITTEN PERMISSION OF JANSVILLE TOOL & MANUFACTURING INC. IS PROHIBITED.

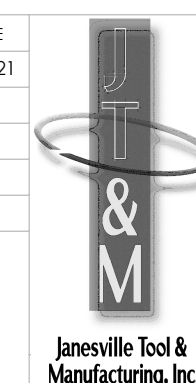

Jansville Tool & Manufacturing Inc.
3930 Enterprise Drive
Jansville, WI 53546
Phone: 608-314-1620, Fax 608-314-1625

TITLE:
P-5604 FOUR STAGE

SIZE DWG. NO. REV
C P-5604-000-00 -

SCALE: 1:8 WEIGHT: 251.90 SHEET 3 OF 3