

OPTIONAL TOOL ADAPTER:  
FOR USE WITH DIE SETS  
(4) LENGTHS AVAILABLE

SECTION Y-Y  
SCALE 1 : 4

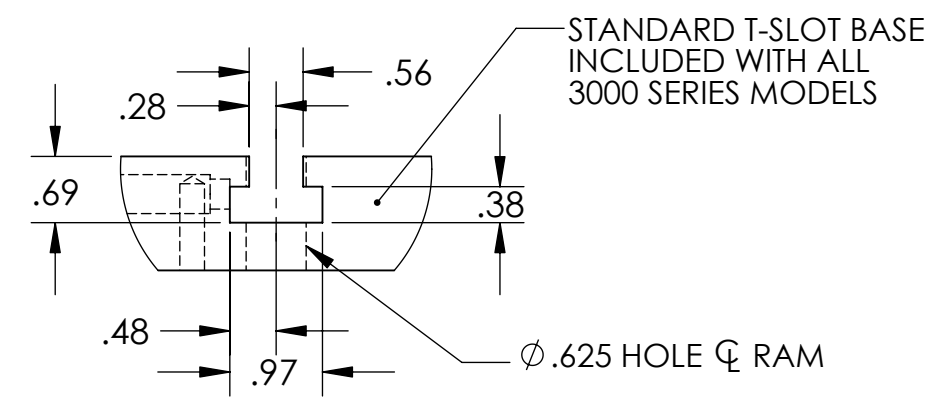

DETAIL X  
SCALE 1 : 2

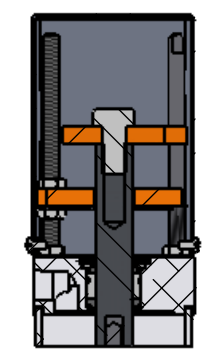

SECTION Z-Z  
SCALE 1 : 4

ADJUSTABLE DOWN STOP/  
ANTI-ROTATE MECH.

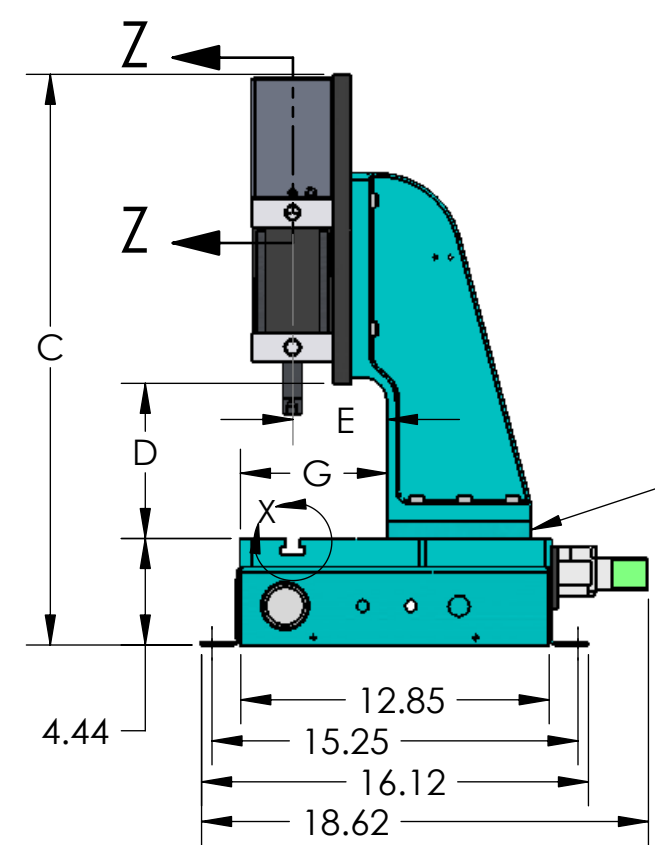
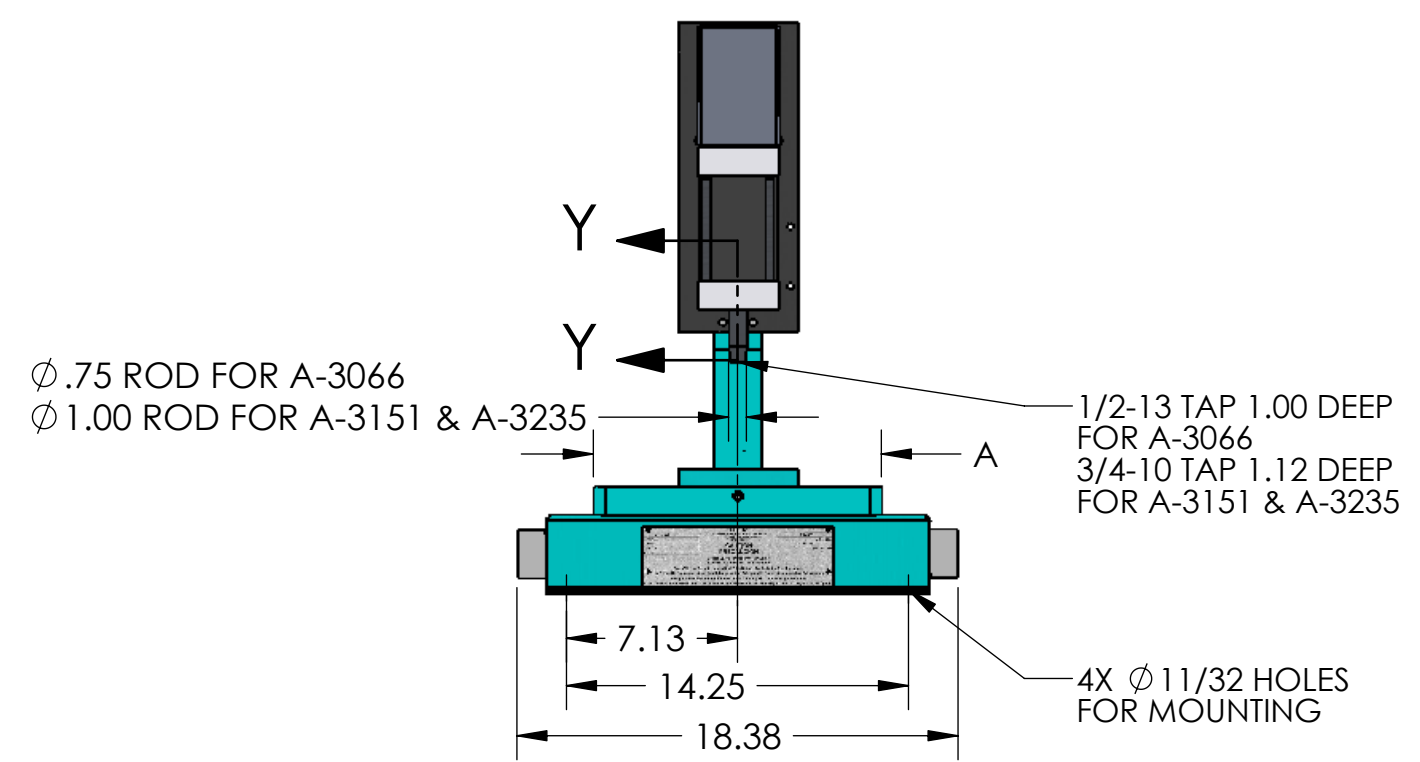

MODEL #	A DIM.	C DIM.	D DIM.	E DIM.	G DIM.
A-3066	12.00	23.78*	6.47	3.94	6.13
A-3151	12.00	23.91*	5.75	4.81	7.00
A-3235	12.00	28.10*	5.75	4.81	7.00

\*OVERALL HEIGHT IS ADJUSTABLE +1.188/-1.188

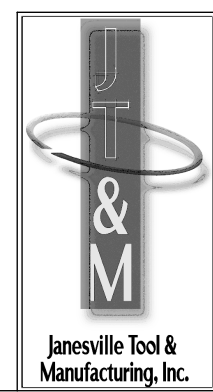

**Janesville Tool & Manufacturing Inc.**  
1352 East High Street  
Milton WI 53563  
Phone 608-868-4711 Fax 608-868-4925  
www.janesvilletool.com

TITLE: A-3000 SERIES		
SIZE: <b>B</b>	DWG. NO.: <b>A-3000</b>	REV: <b>A</b>
SCALE: 1:8	WEIGHT: 103.22	SHEET 1 OF 1