

SECTION B-B
SCALE 1 : 4

ADJUSTABLE DOWNSTOP/
ANTI-ROTATE MECHANISM

VALVE

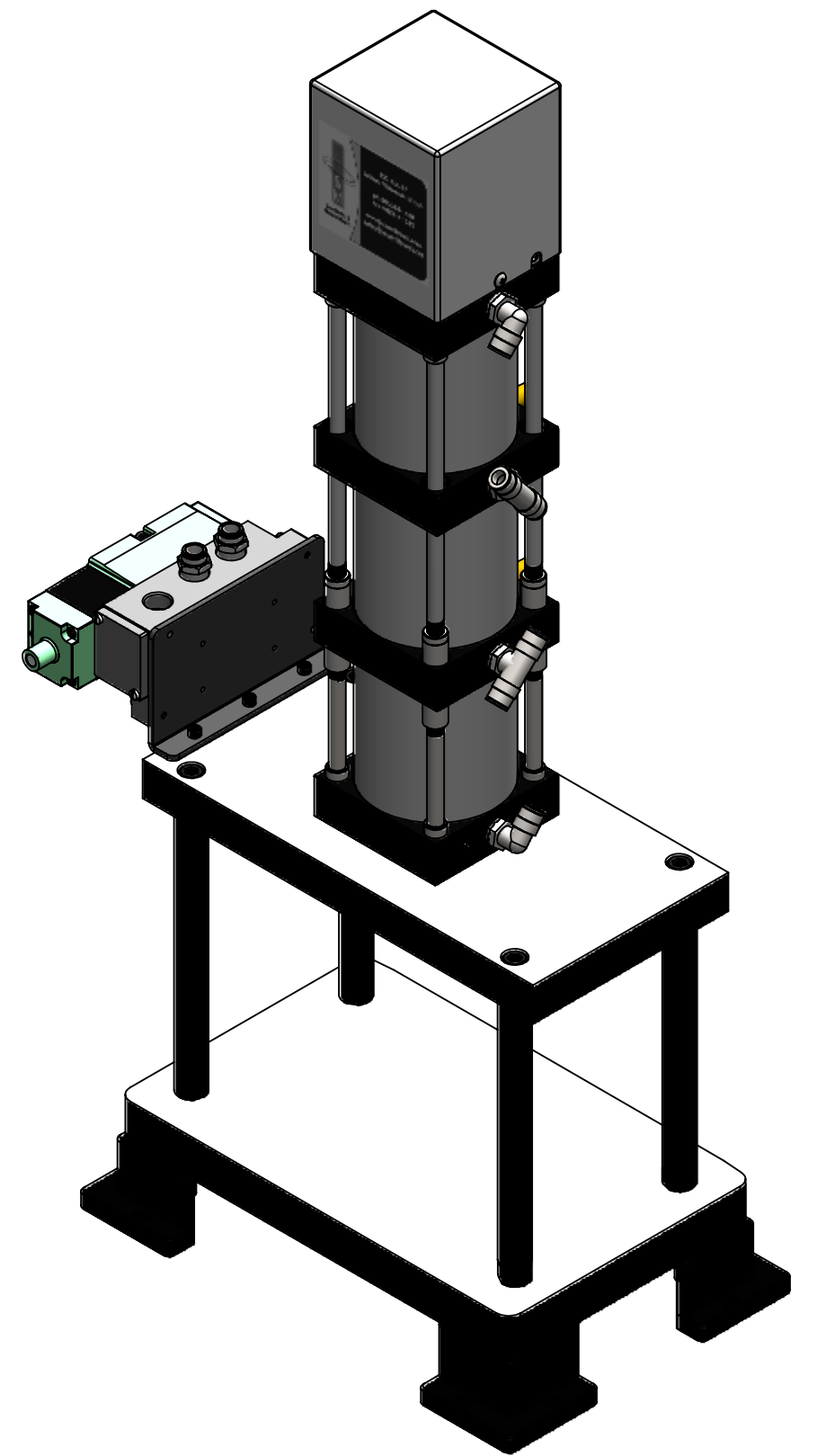
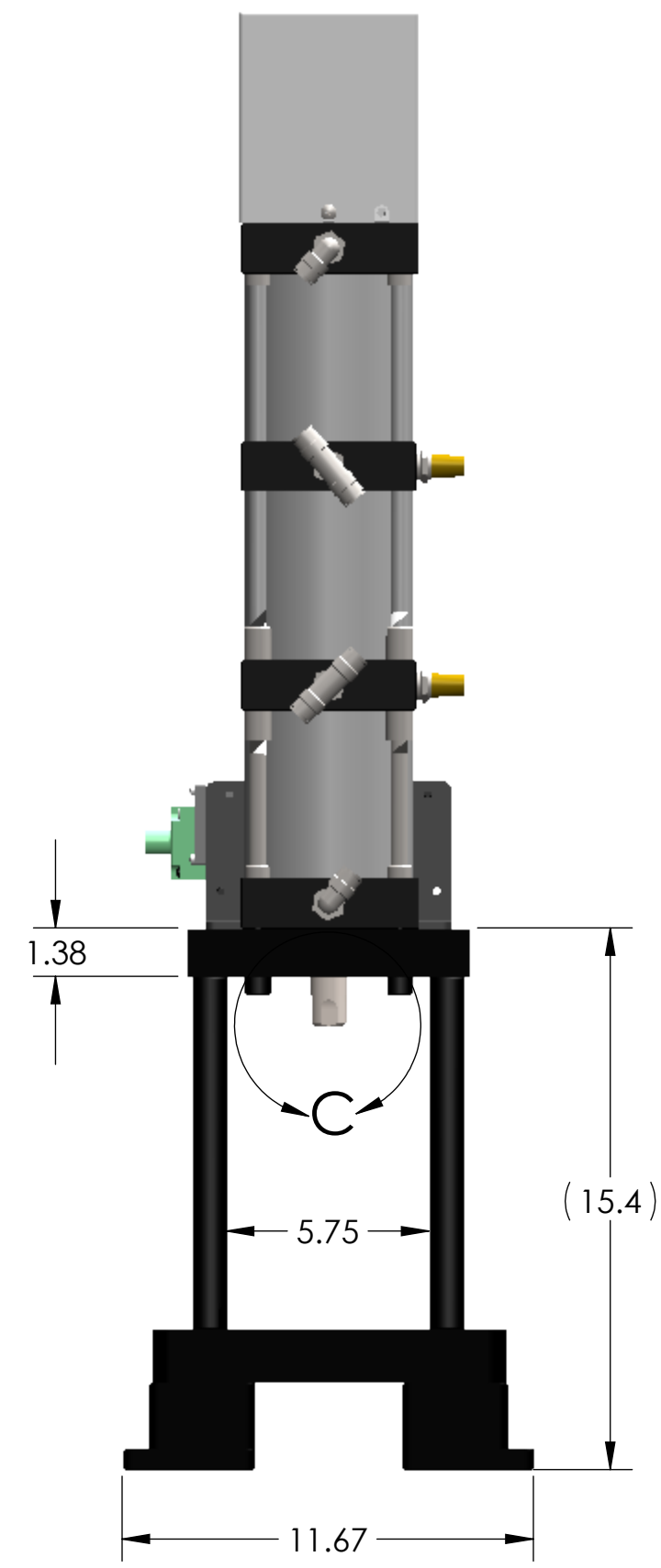
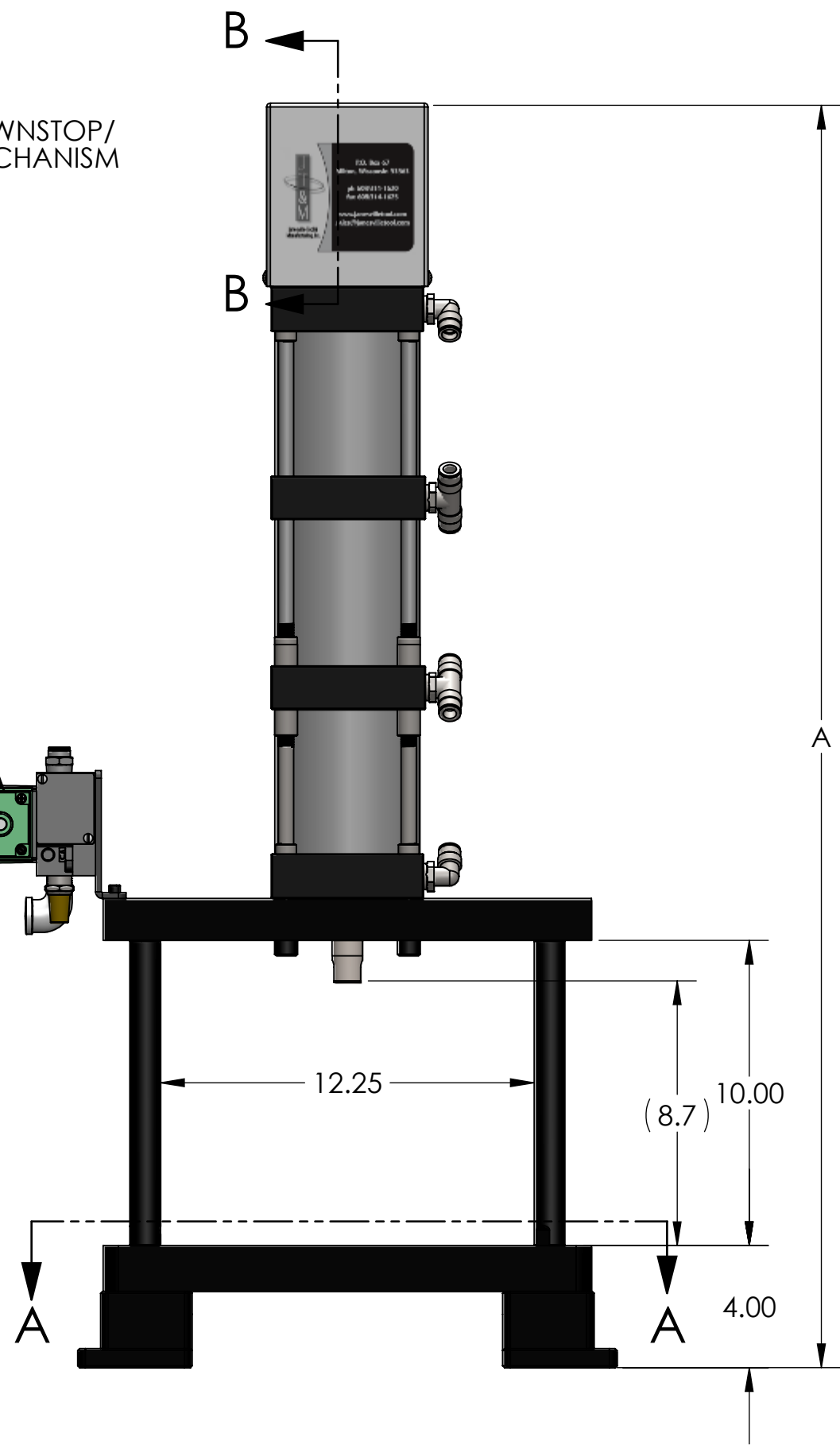

8 X ϕ .33 THRU
 \square ϕ .53 ∇ 1.94

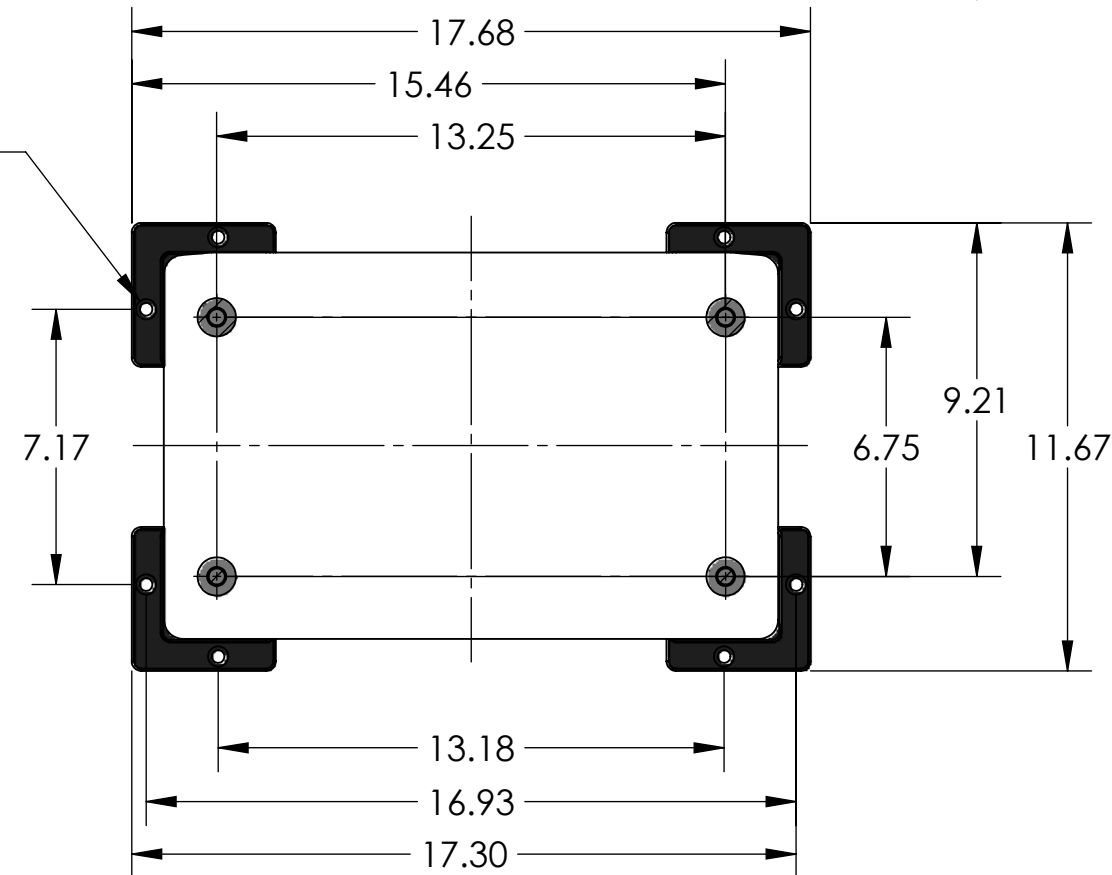

4000-100 (CONTROL BOX ASSEMBLY)
STANDARD WITH A-5000 PRESS

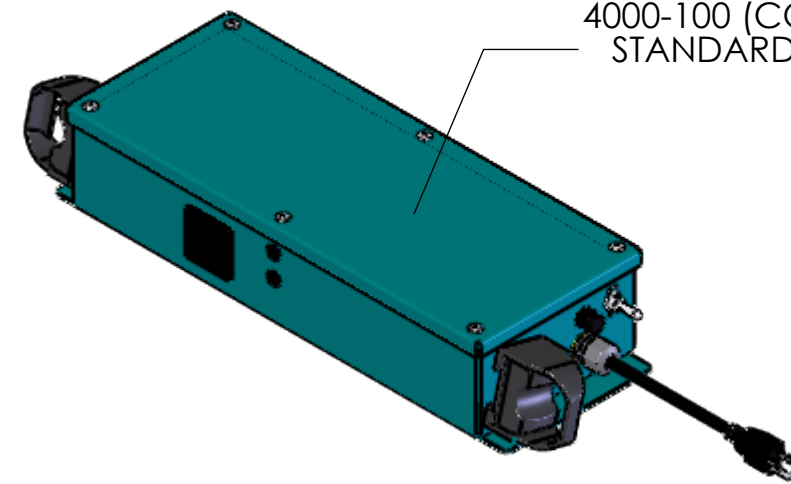

DETAIL C
SCALE 2 : 5

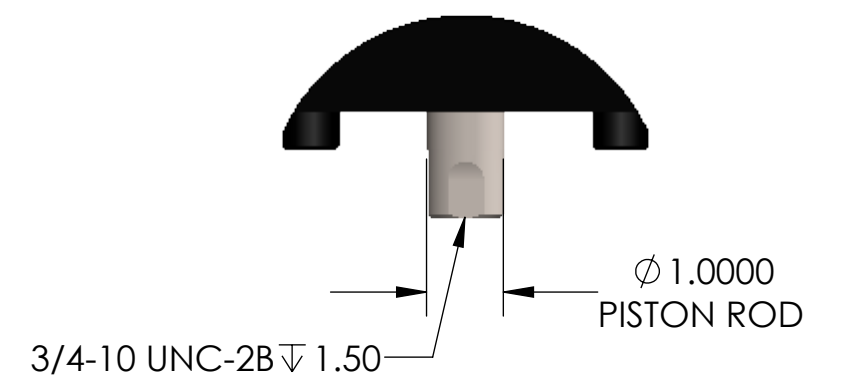

NOTES:

1. A-5353 SHOWN.
2. 10" INCH LONG POSTS STANDARD, OPTIONAL LENGTHS AVAILABLE.
3. 4000-100 CONTROL BOX: 4.00 X 8.25 X 23.69.

MODEL #	DIM A	VALVE	FORCE (@80PSI)
A-5302	35.2	511	2416
A-5353	41.4	546	3624
A-5604	47.7	546	4832

THIS DRAWING WAS PRINTED ON 5/23/2017

UNLESS OTHERWISE SPECIFIED:
DIMENSIONS ARE IN INCHES
TOLERANCES:
FRACTIONAL: \pm 0.15
ANGULAR: MACH \pm 0.5 BEND \pm 0.5
TWO PLACE DECIMAL \pm 0.01
THREE PLACE DECIMAL \pm 0.005
FOUR PLACE DECIMAL \pm 0.0005
INTERPRET GEOMETRIC TOLERANCING PER: ASME Y14.5-1994

DRAWN	NAME	DATE
GSAL	GSAL	5/18/17
CHECKED		
ENG APPR.		
MFG APPR.		

Q.A.
COMMENTS:
BREAK ALL SHARP EDGES

SEE DETAILS
DO NOT SCALE DRAWING

PROPRIETARY AND CONFIDENTIAL
THE INFORMATION CONTAINED IN THIS DRAWING IS THE SOLE PROPERTY OF JANEVILLE TOOL & MANUFACTURING INC. ANY REPRODUCTION IN PART OR AS A WHOLE WITHOUT THE WRITTEN PERMISSION OF JANEVILLE TOOL & MANUFACTURING INC. IS PROHIBITED.

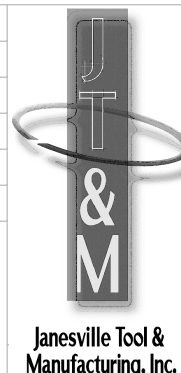

Janesville Tool & Manufacturing Inc.
3930 Enterprise Drive
Janesville, WI 53546
Phone: 608-314-1620, Fax 608-314-1625

TITLE:
A-5353 PRESS NEW

SIZE	DWG. NO.	REV
C	A-5000	-

SCALE: 1:8 | WEIGHT: 211.21 | SHEET 1 OF 1