

AP-810

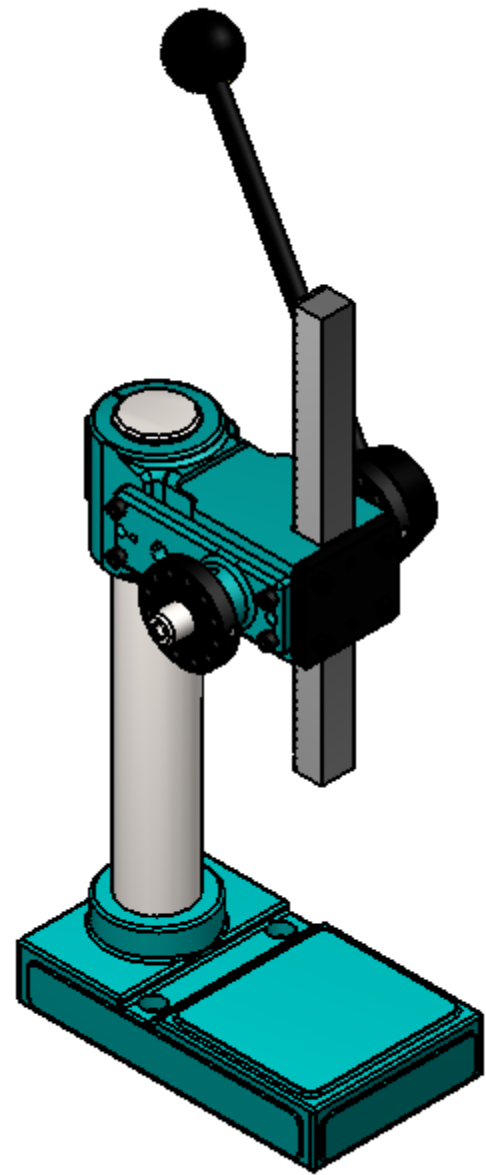

AP-810-AH

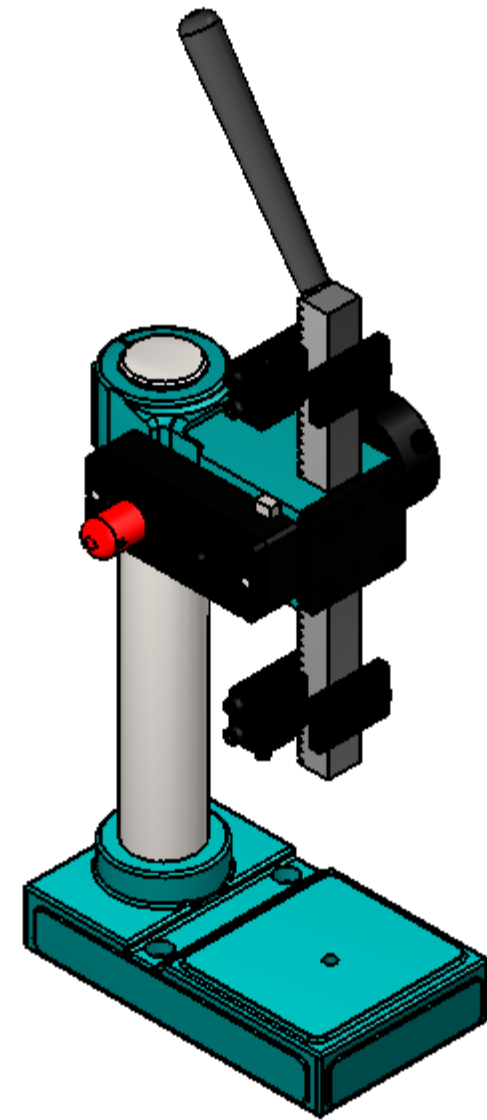

AP-810-FS

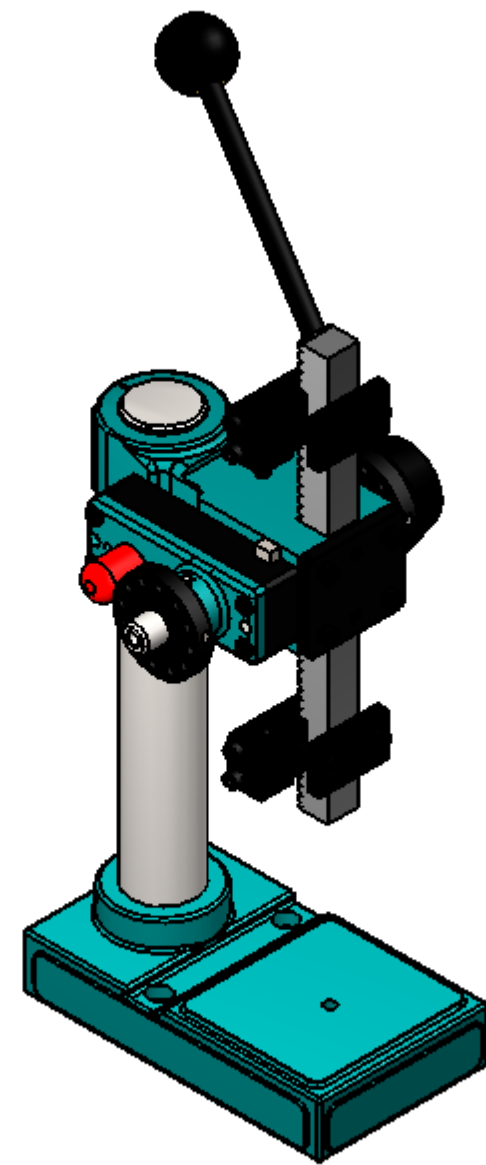

AP-810-FS-AH

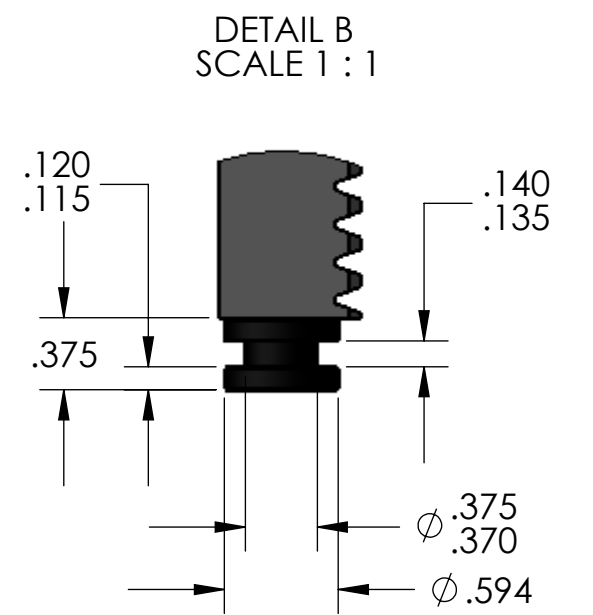
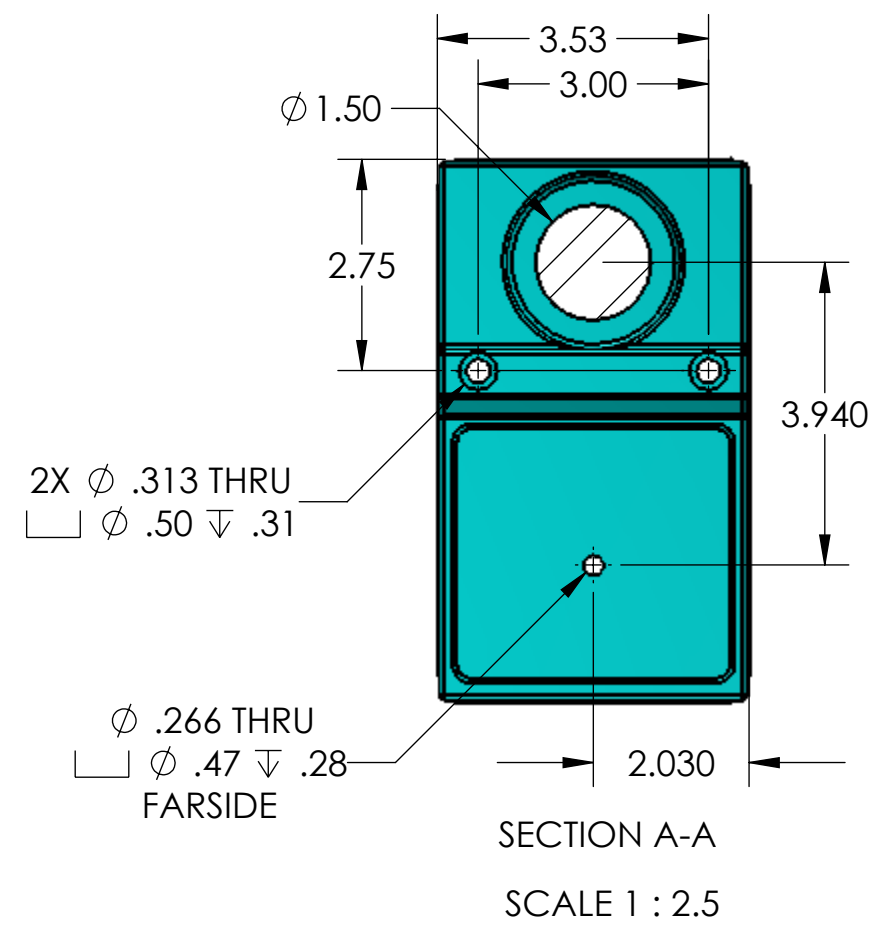
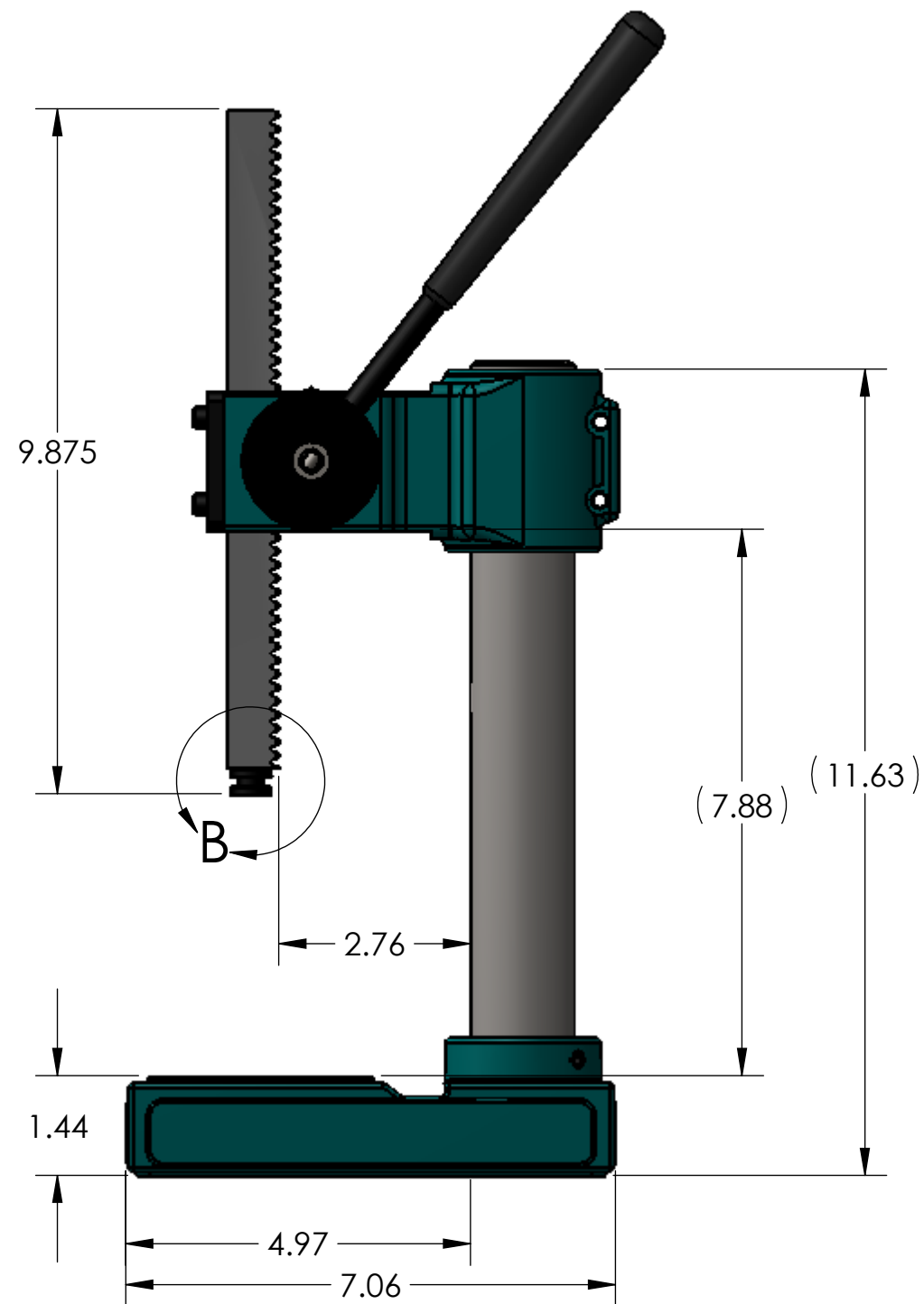
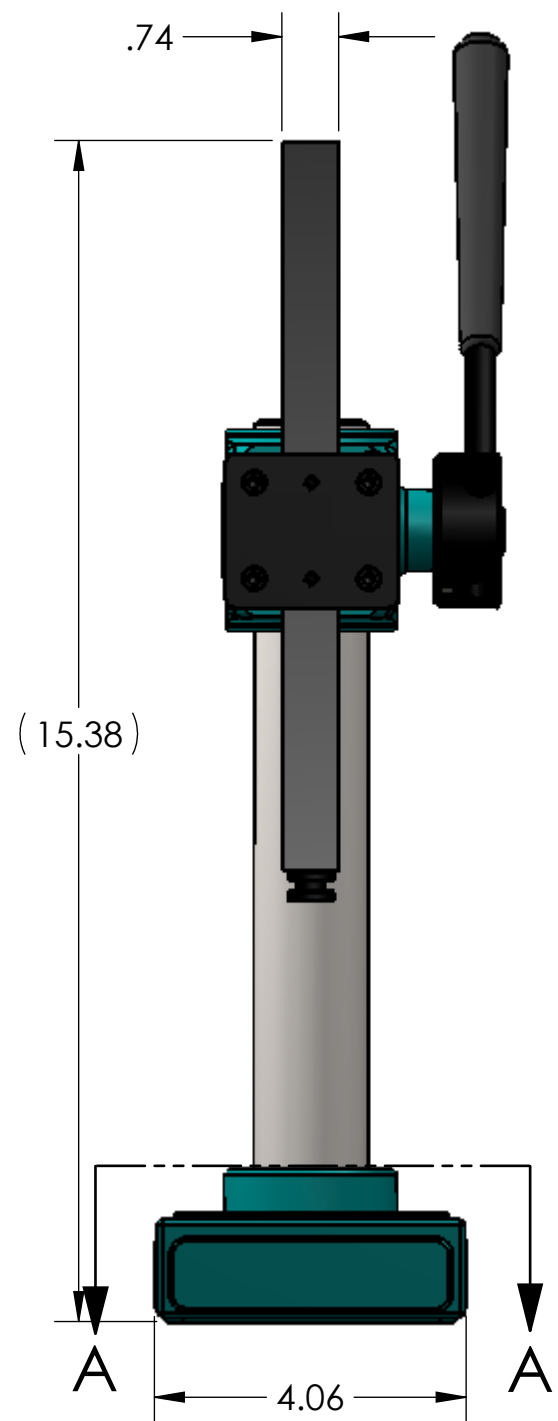

- NOTES:
1. AH MODELS ARE INDEXABLE @ 15° INCREMENTS
 2. ATTACHMENT OPTION IS SHOW IN FRONT AND RIGHT VIEWS
 3. OPTIONAL COLUMN LENGTHS AVAILABLE
 4. ADJUSTABLE HEAD HEIGHT
 5. HANDLE IS $\varnothing 3/8" \times 6.0$ LG

 Janesville Tool & Manufacturing, Inc.	Janesville Tool & Manufacturing Inc. 3930 Enterprise Drive Janesville, WI 53546 Phone: 608-314-1620, Fax 608-314-1625		
	TITLE: AP-810 PRESS		
	SIZE C	DWG. NO. AP-810 SERIES	REV -
	SCALE: 1:8	WEIGHT: 22.94	SHEET 1 OF 1