

AP-810-RR-A

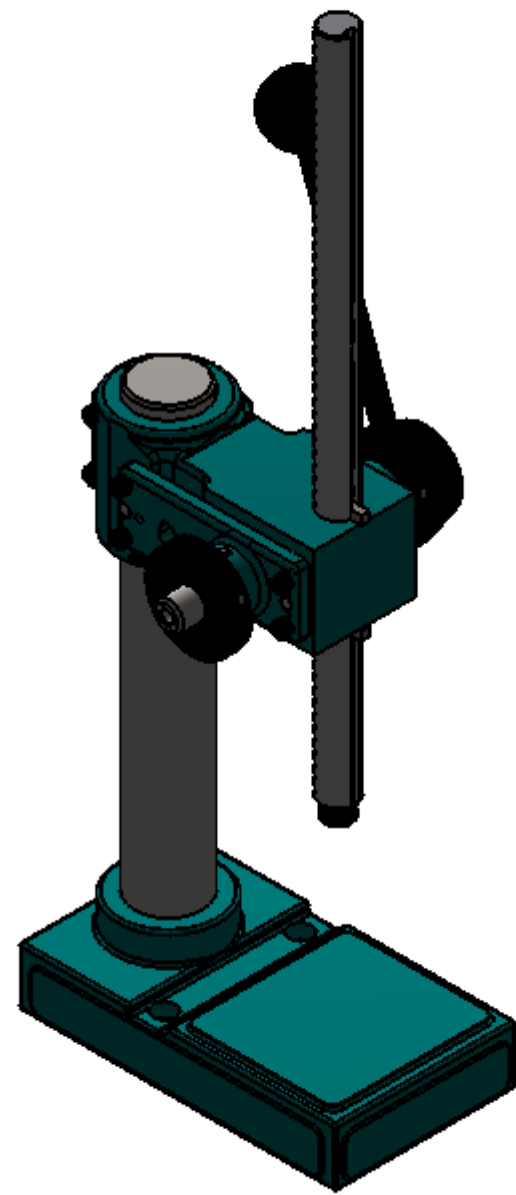

AP-810-RR-AH

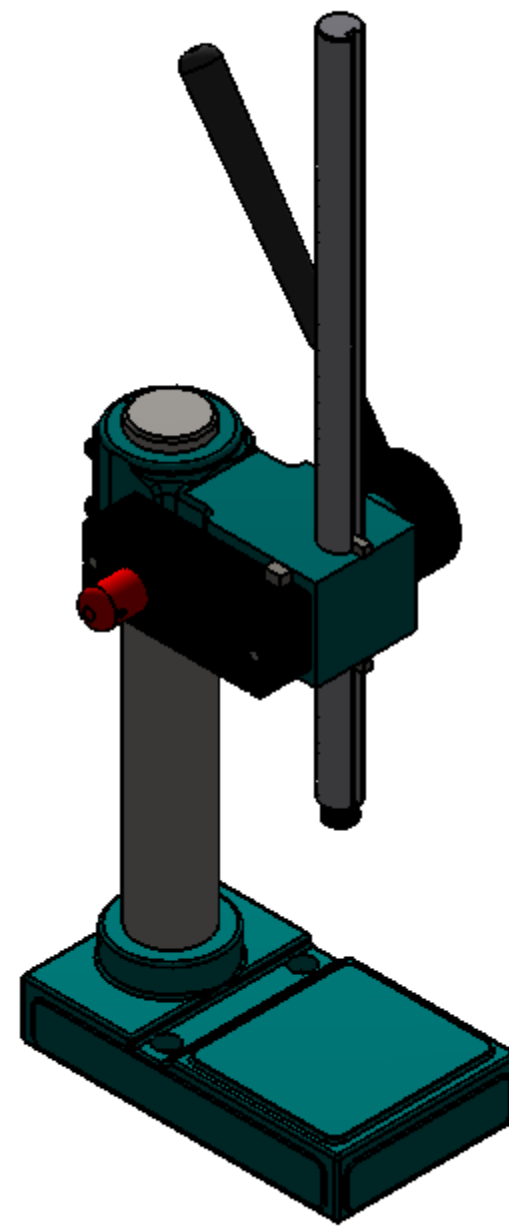

AP-810-RR-FS

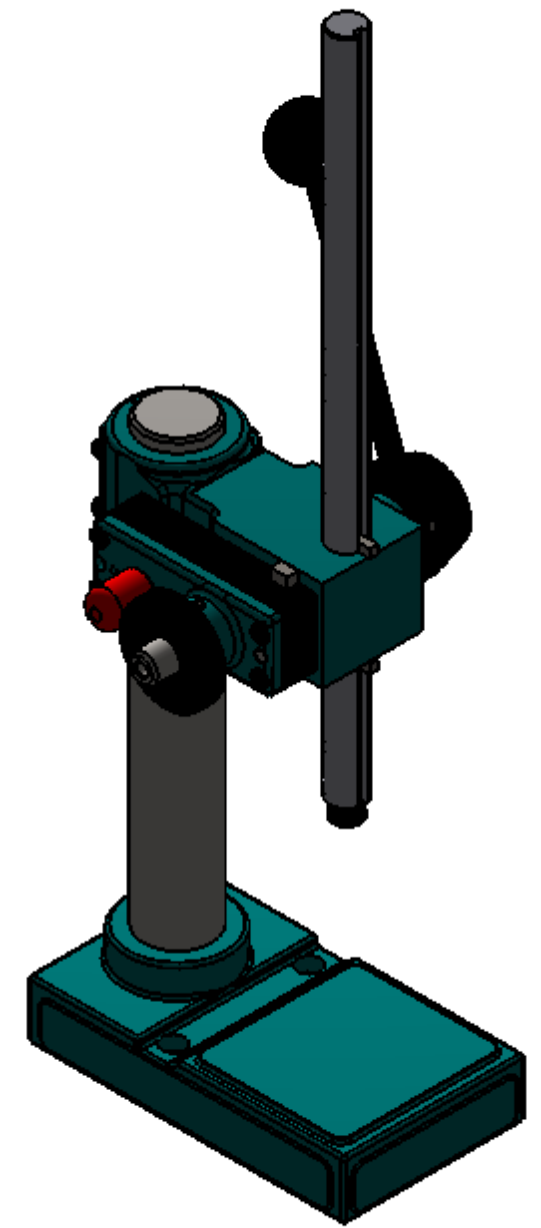

AP-810-RR-AH-FS

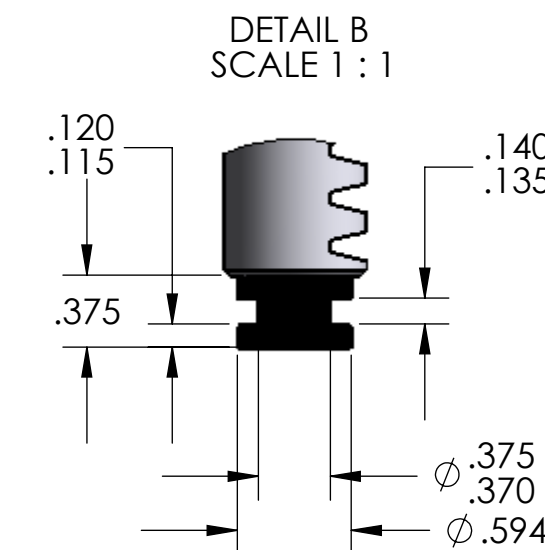
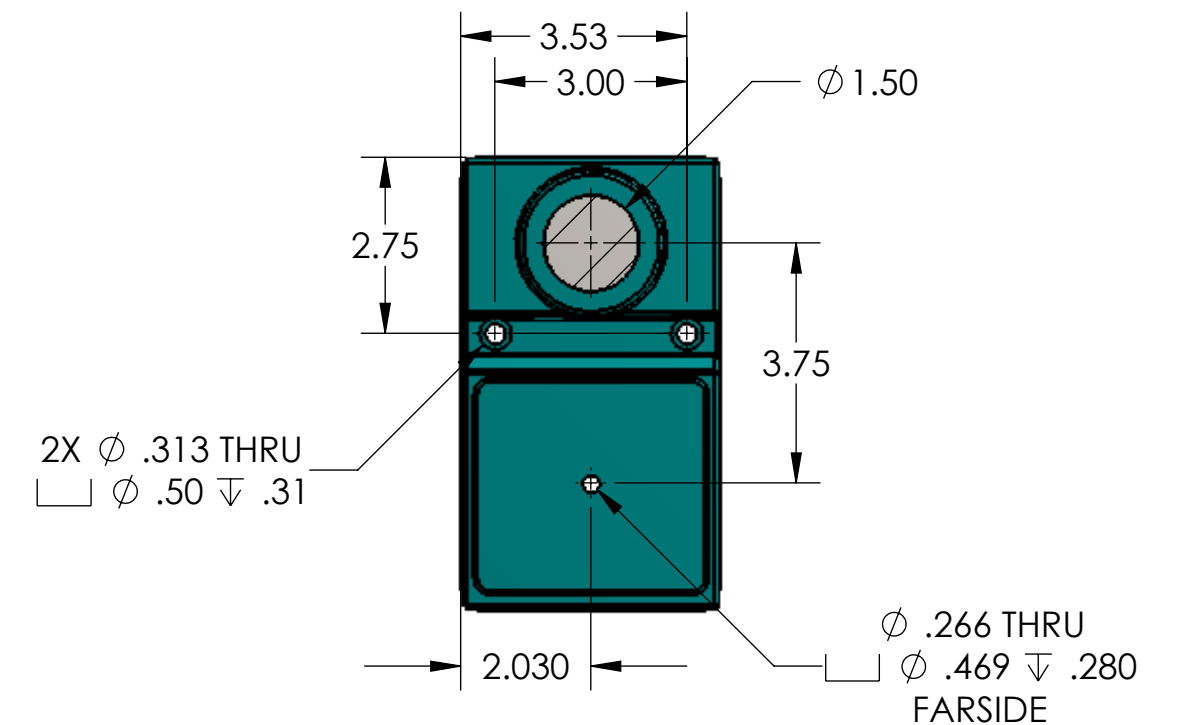
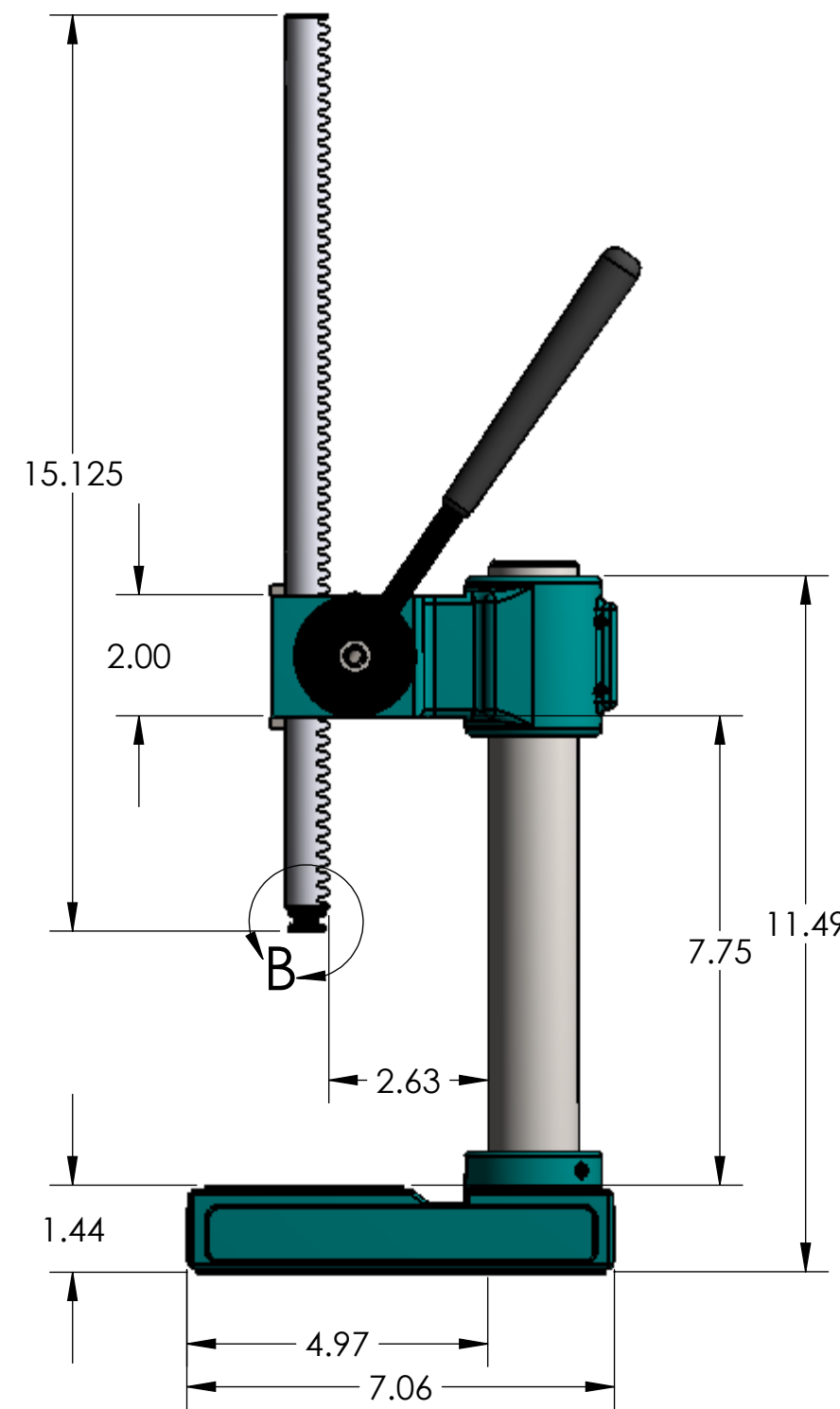
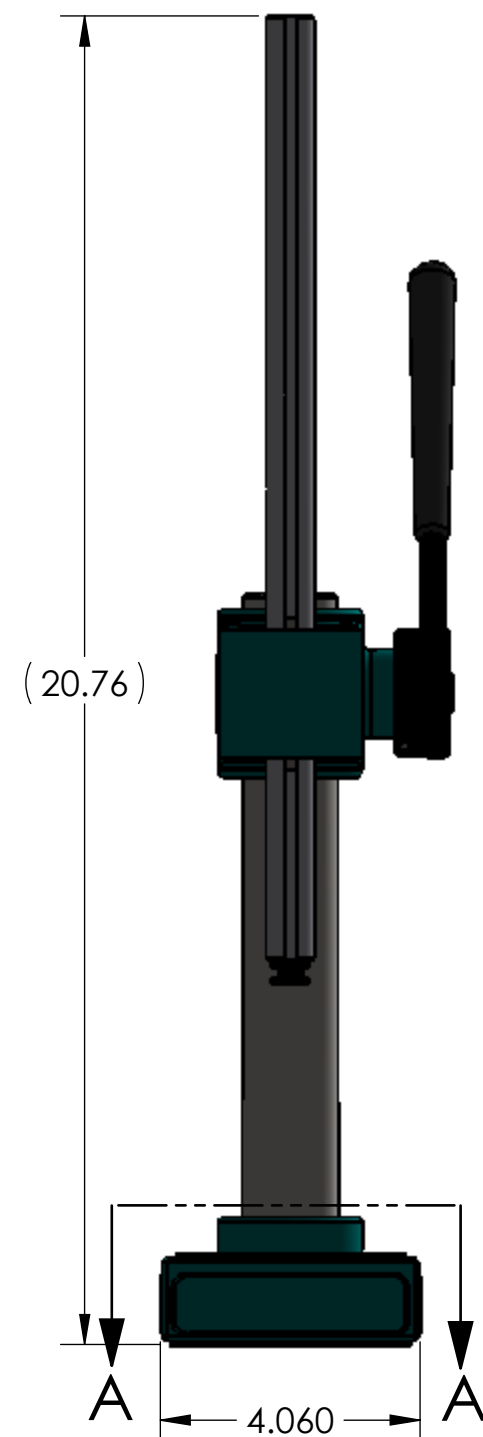

NOTES:

1. AH MODELS ARE INDEXABLE @ 15° INCREMENTS
2. ATTACHMENT OPTION IS SHOW IN FRONT AND RIGHT VIEWS
3. OPTIONAL COLUMN LENGTHS AVAILABLE
4. ADJUSTABLE HEAD HEIGHT
5. HANDLE IS $\phi 3/8"$ X 6.0 LG

	Janesville Tool & Manufacturing Inc. 3930 Enterprise Drive Janesville, WI 53546 Phone: 608-314-1620, Fax 608-314-1625		
	TITLE: AP-810 PRESS ROUND RAM		
	SIZE C	DWG. NO. AP-810-RR SERIES	REV -
	SCALE: 1:8	WEIGHT:	SHEET 1 OF 1