

DETAIL A
SCALE 2 : 1
SLOT FOR 5/16 T-BOLT

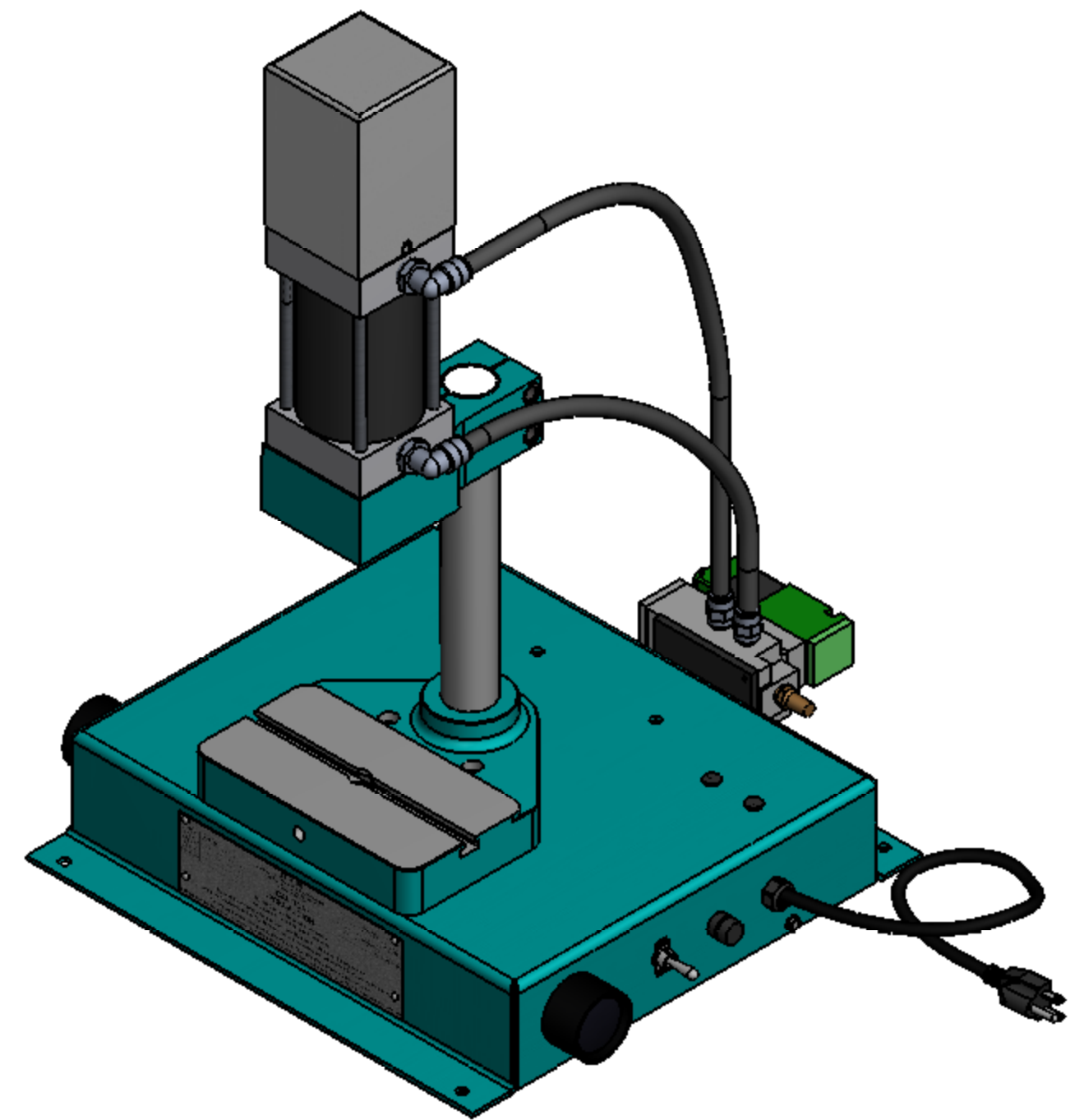
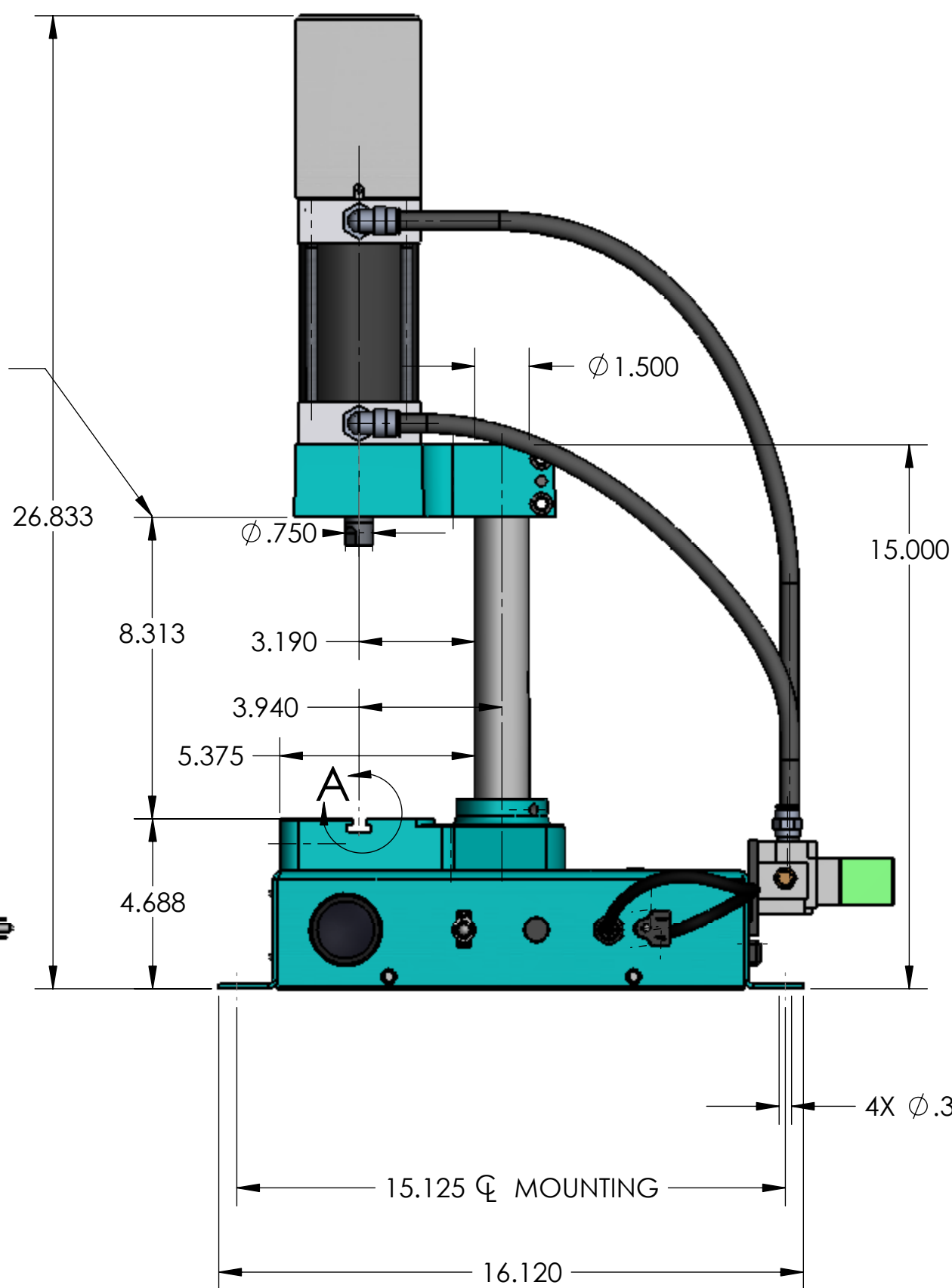
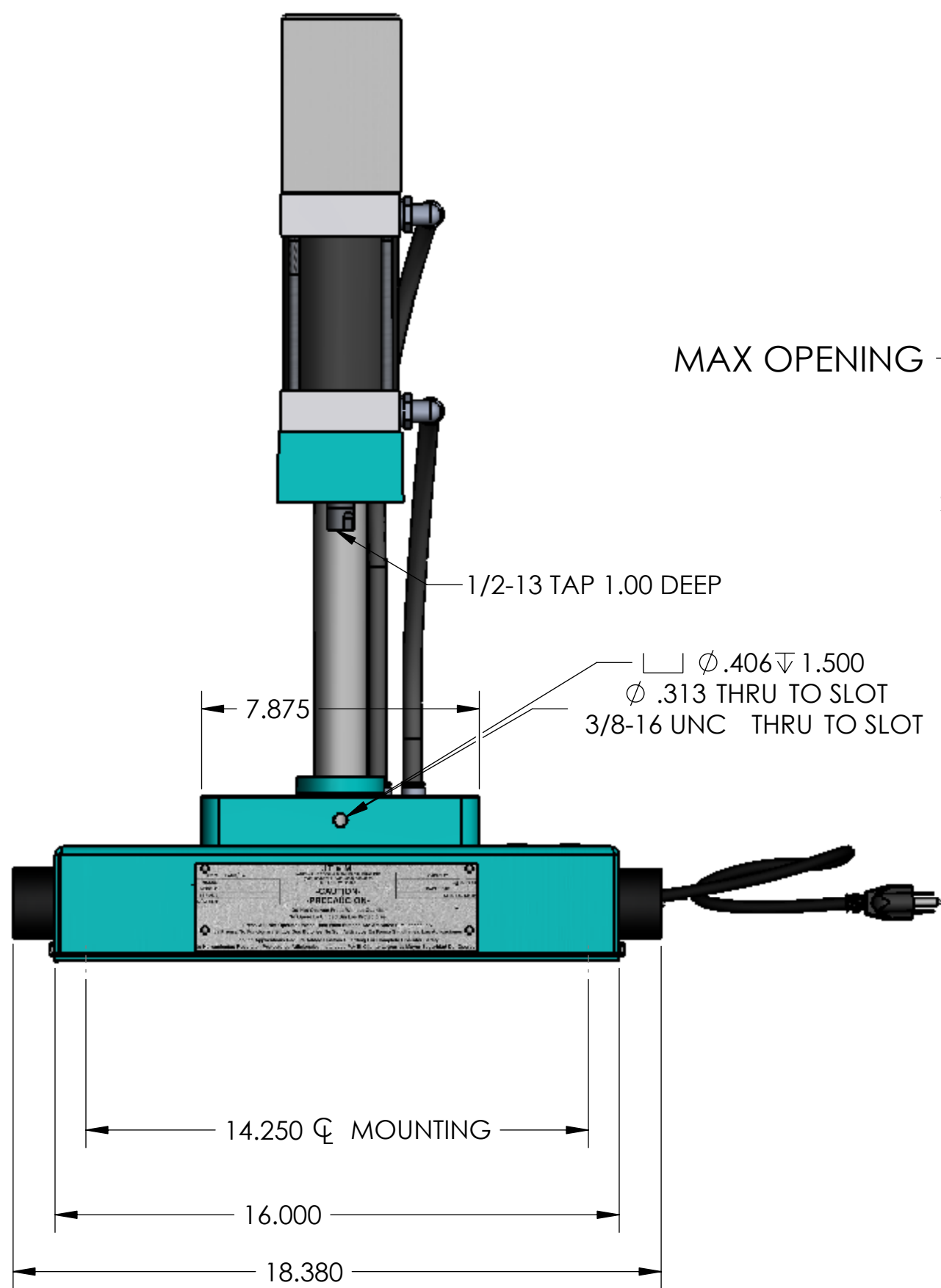

4X Ø .344 THRU MOUNTING

THIS DRAWING PRINTED 3/5/2009

UNLESS OTHERWISE SPECIFIED:

DIMENSIONS ARE IN INCHES
TOLERANCES:
FRACTIONAL ± 0.15
ANGULAR: MACH ± 0.5 BEND ± 0.5
TWO PLACE DECIMAL ± 0.01
THREE PLACE DECIMAL ± 0.005
FOUR PLACE DECIMAL ± 0.0005

INTERPRET GEOMETRIC TOLERANCING PER:

MATERIAL: ASSEMBLY
FINISH: DO NOT SCALE DRAWING

NAME	DATE
DRAWN: KLS	
CHECKED:	
ENG APPR.:	
MFG APPR.:	
Q.A.:	
COMMENTS:	

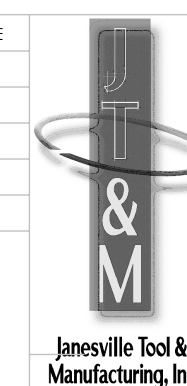

JOB #	DATE	MACHINIST	TIME

Janesville Tool & Manufacturing Inc.
1352 East High Street
Milton WI 53563
Phone 608-868-4711 Fax 608-868-4925

TITLE:
A-2000 PRESS

SIZE: C	DWG. NO.: A-2066	REV:
----------------	-------------------------	------

SCALE: 1:8 WEIGHT: 63.75 SHEET 1 OF 1

PROPRIETARY AND CONFIDENTIAL
THE INFORMATION CONTAINED IN THIS DRAWING IS THE SOLE PROPERTY OF JANESVILLE TOOL & MANUFACTURING INC. ANY REPRODUCTION IN PART OR AS A WHOLE WITHOUT THE WRITTEN PERMISSION OF JANESVILLE TOOL & MANUFACTURING INC. IS PROHIBITED.