

AP - 810

The AP-810 Adjustable Lever Press is rated to withstand 1000 lbs. of force. This precision assembly press is ideal for small parts assembly, punching, shearing, and staking of light-gauge stock, metal, or plastic. The head can be adjusted for height with two (2) clamp screws. The press contains a 3/4" square ground ram and an adjustable gib for continual accuracy.

Options:

- Stroke Limiters (Model SL)
- Multiposition Fixture (Model 0632)
- Die Sets (See Page 16)
- Longer Column
- Counter & Bracket (Model PC-810)
- Adjustable Handle Add suffix (-AH)
- Arrange Press For Die Set Mtg. Add suffix (-A)
- 12" Lg. Rack



The AP-810-RR Adjustable Lever Press is rated to withstand 1000 lbs. of force. This precision assembly press is ideal for pressing, punching, small parts assembly, shearing, crimping, and staking. The head of the press can be adjusted for height with (2) clamping screws. The press contains a 3/4" diameter keyed ram that is 14 3/4" long, which will enable the user to utilize a longer column for longer strokes.

Options:

- Up-Stroke Limiters (Model 967-09)
- Down Stops (Model 967-10)
- Multiposition Fixture (Model 0632)
- Die Sets (See Page 16)
- Counter & Bracket (Model PC-810-RR)
- Longer Column
- Adjustable Handle Add suffix (-AH)
- Arrange Press For Die Set Mtg. Add suffix (-A)

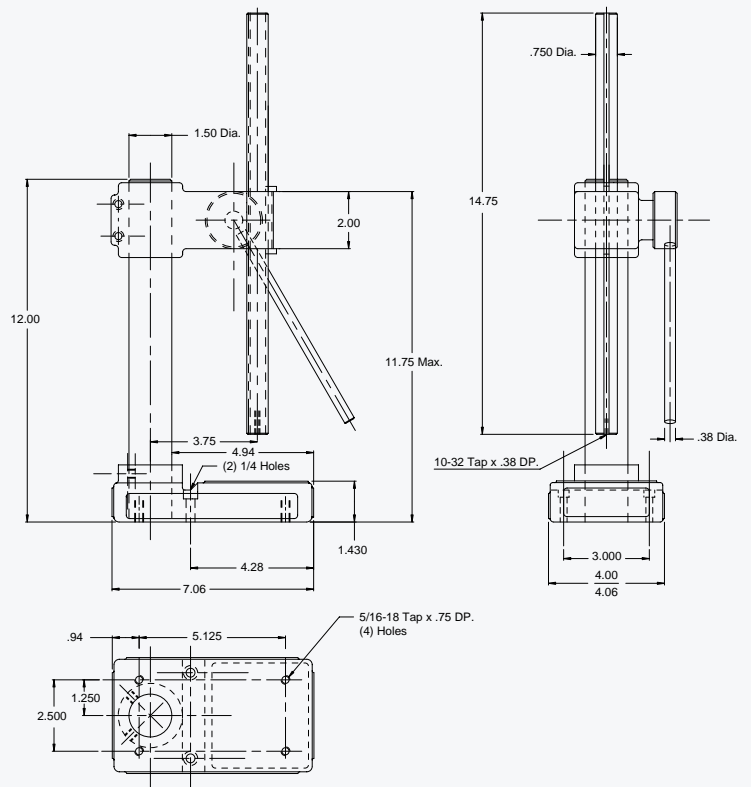

AP - 810-RR